

CESSNA 172

WALK-AROUND CHECK AND VISUAL INSPECTION

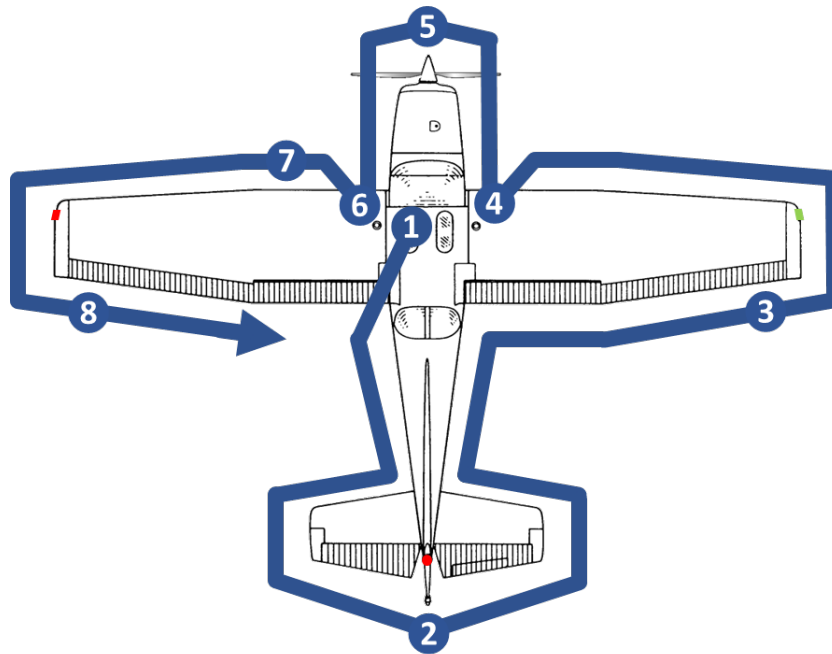

1 CABIN

Airplane documents..... CHECKED
 Gust lock & Pitot cover REMOVED AND STOWED
 Parking brake ON
 Ignition key OFF
 Canopy CLEAN
 All circuit breakers IN
 Master Switch ON
 Fuel Quantity Indicators..... CHECK QUANTITY
 Flaps DOWN
 All aircraft lights ON, CHECK OPERATION
 All aircraft lights OFF
 Master Switch OFF
 HOBBS and VUT CHECKED
 Foreign object inspection in cabin CHECKED
 Emergency Locator Transmitter (ELT) AUTO or ARM

2 EMPENNAGE AND TAIL

Baggage door CHECK LOCKED
 Control Surfaces CHECK FREEDOM

3 RIGHT WING – Trailing Edge

Flap CHECK FOR SECURITY & CONDITION
 Aileron CHECK FREEDOM OF MOVEMENT & SECURITY

4 RIGHT WING

Main Wheel Tire CHECK FOR PROPER INFLATION
 Fuel Tank Sump SAMPLE
 Fuel Quantity CHECK VISUALLY
 Fuel Filler Cap SECURE

5 NOSE

Engine Oil Level..... CHECK MIN 5 MAX 7 QUARTS
 Fuel Strainer DRAIN
 Propeller and Spinner CHECK FOR NICKS AND SECURITY
 Landing Light CHECK CLEANLINESS
 Air Filter CHECK FOR FOREIGN MATTER
 Nose Gear Shock Strut..... CHECK FOR PROPER INFLATION
 Nose Wheel Tire CHECK FOR PROPER INFLATION
 Static Source Opening CHECK FOR BLOCKAGE

6 LEFT WING

Main Wheel Tire..... CHECK FOR PROPER INFLATION
 Fuel Tank Sump SAMPLE
 Fuel Quantity CHECK VISUALLY
 Fuel Filler Cap SECURE

7 LEFT WING – Leading Edge

Pitot tube..... CHECK OPENING FOR BLOCKAGE
 Fuel Tank Vent Opening.. CHECK OPENING FOR BLOCKAGE
 Stall Warning Opening CHECK OPENING FOR BLOCKAGE

8 LEFT WING – Trailing Edge

Aileron... CHECK FREEDOM OF MOVEMENT AND SECURITY
 Flap..... CHECK FOR SECURITY AND CONDITION

WALK-AROUND CHECKLIST COMPLETED



AEROCLUB HILVERSUM-AMSTERDAM



NL-ATO-227