

# PROCEDURES CESSNA 172

PH-SKC

PH-JBC

PH-DON



PROCEDURES-C172 – EN – VERSION 2.0 – 01.05.2026

[info@vliegclubhilversum.nl](mailto:info@vliegclubhilversum.nl)



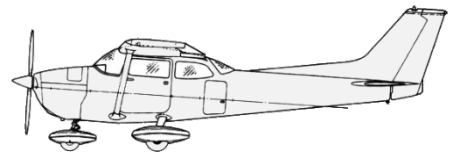
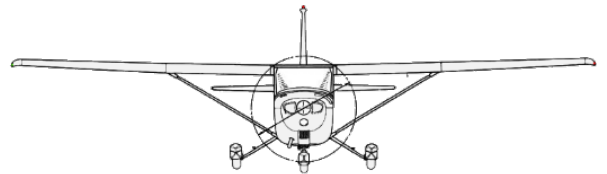
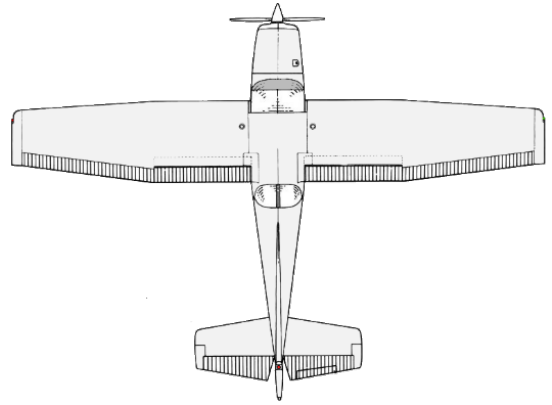

**Authors:**

Mark van den Burg, Sietse Visser, Mario Nienhuis, Norman Seeger, Eric Gillisse

**Commissioned by:**

Aero Club Hilversum-Amsterdam (ACHA) (OSCAR - NL-ATO-227) See: <https://vliegclubhilversum.nl/>

**Drawings and Design:**

Mario Nienhuis, [info@basic6aviation.com](mailto:info@basic6aviation.com)

**Copyright © 2026**

All rights reserved. No part of this publication may be duplicated or transmitted in any form without the author's written permission.

**Disclaimer:**

This publication has been compiled with the greatest care. However, neither the authors nor the ACHA assume any liability for any damages resulting from any inaccuracies and/or omissions in this publication. Despite the information in this release, the official Pilot's Operating Handbook (POH) should always be used and takes precedence over the information contained in this publication.

# Contents

## **Revision record**5

## **Preflight Procedures**6

Walk-Around check and visual inspection6

## **Departure and approach briefing & threat and error management**11

Preparation for briefing:11

Radio telephony examples13

## **General Aircraft Information**16

Cockpit layout (PH-DON)16

## **General information**17

Power setting / configuration versus speed table18

## **Normal procedures**19

General advice19

Structured scanflow20

## **Manoeuvres**22

Straight and level flight23

Transition from straight and level flight to climb24

Transition from straight level flight to descending flight25

Transition from descent to straight and level flight25

Transition from straight and level to glide26

Clearing the engine during glide26

Transition from glide to straight and level flight27

Level turn27

Climbing turn28

Descending turn29

Steep turn (45°)30

Slow flight  $V_s + 10$ 31

## **Air Exercises**32

Stall with flaps up34

Stall with flaps down35

Approach to stall in climbing turn without flaps36

Approach to stall in climbing turn with flaps in takeoff configuration (Flaps 10°)36

## **Circuit procedures**38

VFR circuit38

## **Takeoff procedures**39

Normal takeoff39

Soft or rough field takeoff40

Obstacle clearance takeoff (short field takeoff)40

## **Enroute procedures**41

Enroute climb41

Cruise41

Approach41

Downwind check41

## **Landing procedures**42

Circuit and normal landing42

Normal landing42  
Flaps up landing43  
Soft field landing44  
Short field landing45  
Go-Around, balked landing45  
Touch and go45  
Circuit with low ceilings/visibility weather46  
Circuit with turbulent weather46  
Crosswind techniques46

**Abnormal procedures48**

Rejected takeoff48  
Engine failure after takeoff (EFATO)48  
Engine failure during flight49  
Emergency landing without engine power49  
Estimated gliding distance51  
Wind affects gliding range over the ground52  
Precautionary landing53

**Important links55**

**Notes:56**

**APPENDIX57**

**Checklist PH-DON57**

**APPENDIX Checklist PH-JBC en Afwijkingen59**

## Revision record

### Revision pages from version 1.0

REVISION NUMBER:	REVISION DATE:	TOTAL PAGES:	REVISED PAGES:	NOTES:
1.8	27-12-2022	47	ALL	INCLUSION RADIO PROCEDURES, RE ORDERING OF PROCEDURES
1.7	08-04-2023	ALL	ALL 14 AND 15 SPECIFIC	LAYOUT AND IMAGES ADAPTED TO LATEST CHANGES CF OTHER MANUALS AND CHECKLISTS. PWR SETTING TABLE AND TAXI CHECKS
1.8	01-05-2024	ALL	ALL	WALKAROUND OIL LEVEL CHANGE CLIMB PROCEDURE CHANGE MIN ALT FOR MANOUVERS CHANGED CF OM PROCEDURE T&G ADDED FLAPS SELECTION PROCEDURE CHANGE
1.9	01-04-2025	ALL	ALL	ADDED NORMAL AND ABNORMAL CHECKLIST ADDED ITEM BRIEFING IN NORMAL C/L AND ADDED BRIEFING PROCEDURE CHANGED MEMORY ITEMS EMERGENCY C/L CHANGED MAX T/O WEIGHT UTILITY CATEGORY ADDED STALL EXERCISE CHANGED CLIMB OUT TEXT IN T/O PROCEDURE
1.9	01-04-2025	ALL	ALL	TEXTURAL CHANGE SOFT FIELD TAKEOFF CHANGED DOWNWIND SPEED AND NOTE FOR FINAL APPROACH SPEED ADDED APPENDICES FOR C-172
2.0	01-05-2026	ALL	ALL	TEXTUAL CHANGES ADDED NORMAL PROCEDURES MINOR CHANGES IN PROCEDURES ADDED R/T PROCEDURES EHHV ADDED STALL WARNING CHECK W/A C/L ADDED LOSSE ITEMS STOW NORMAL C/L

# Preflight Procedures

## Walk-Around check and visual inspection

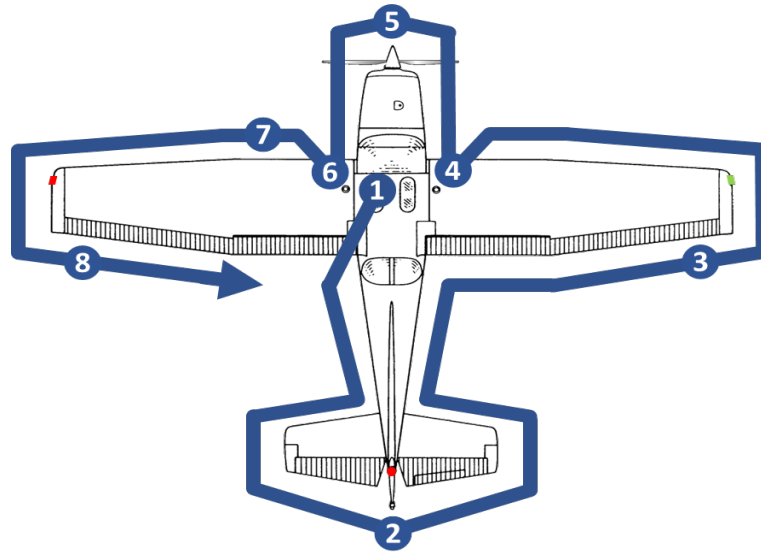

### 1 CABIN

Airplane documents..... CHECKED  
Gust lock & Pitot cover ..... REMOVED AND STOWED  
Parking brake ..... ON  
Ignition key ..... OFF  
Canopy ..... CLEAN  
All circuit breakers ..... IN  
Master Switch ..... ON  
Fuel Quantity Indicators..... CHECK QUANTITY  
Flaps.....DOWN  
All aircraft lights .....ON, CHECK OPERATION  
All aircraft lights ..... OFF  
Master Switch ..... OFF  
HOBBS and VUT..... CHECKED  
Foreign object inspection in cabin ..... CHECKED  
Emergency Locator Transmitter (ELT) .....AUTO or ARM

### 2 EMPENNAGE AND TAIL

Baggage door ..... CHECK LOCKED  
Control Surfaces..... CHECK FREEDOM

### 3 RIGHT WING – Trailing Edge

Flap .....CHECK FOR SECURITY & CONDITION  
Aileron ..... CHECK FREEDOM OF MOVEMENT & SECURITY

### 4 RIGHT WING

Main Wheel Tire .....CHECK FOR PROPER INFLATION  
Fuel Tank Sump ..... SAMPLE  
Fuel Quantity ..... CHECK VISUALLY  
Fuel Filler Cap ..... SECURE

### 5 NOSE

Engine oil level.....PH-DON/PH-SKC MIN 5 MAX 7 QRTS  
..... PH-JBC MIN 6 MAX 8 QRTS  
Fuel Strainer.....DRAIN  
Propeller and Spinner..... CHECK FOR NICKS AND SECURITY  
Landing Light..... CHECK CLEANLINESS  
Air Filter ..... CHECK FOR FOREIGN MATTER  
Nose Gear Shock Strut ..... CHECK FOR PROPER INFLATION  
Nose Wheel Tire..... CHECK FOR PROPER INFLATION  
Static Source Opening ..... CHECK FOR BLOCKAGE

### 6 LEFT WING

Main Wheel Tire ..... CHECK FOR PROPER INFLATION  
Fuel Tank Sump ..... SAMPLE  
Fuel Quantity .....CHECK VISUALLY  
Fuel Filler Cap ..... SECURE

### 7 LEFT WING – Leading Edge

Pitot tube .....CHECK OPENING FOR BLOCKAGE  
Fuel Tank Vent Opening.. CHECK OPENING FOR BLOCKAGE  
Stall Warning...CHECK & CHECK OPENING FOR BLOCKAGE

### 8 LEFT WING – Trailing Edge

Aileron.. CHECK FREEDOM OF MOVEMENT AND SECURITY  
Flap ..... CHECK FOR SECURITY AND CONDITION

**WALK-AROUND CHECKLIST COMPLETED**

# NORMAL CHECKLISTS C-172 PH-SKC

Perform blue checklist items from memory

VFR DAY  
ONLY



## BEFORE STARTING ENGINE

Gust lock & pitot cover ..... REMOVED & STOWED  
Walk-around and visual inspection ..... COMPLETED  
Aircraft documents ..... ON BOARD  
Seats & seatbelts ..... ADJUSTED & SECURED  
Departure/pax briefing ..... COMPLETED  
Doors & windows ..... CLOSED & LOCKED  
Parking brake ..... SET  
Fuel selector ..... BOTH  
All electrical switches ..... OFF  
Avionics masters switch ..... OFF  
Circuit breakers ..... IN  
Master switch ..... ON  
Fuel quantity ..... CHECKED  
HOBBS & VUT ..... NOTED

## STARTING ENGINE

Mixture ..... RICH  
Carburetor heat ..... OFF  
Prime ..... AS REQUIRED & LOCKED  
Throttle ..... 1 CM  
Beacon light ..... ON  
Propeller ..... CLEAR  
Ignition switch ..... START

## AFTER STARTING ENGINE

Throttle ..... 1000 RPM  
Oil pressure ..... (by memory) CHECK  
Starter warning light ..... (by memory) OFF  
Ammeter ..... CHARGING (+)  
Flaps ..... UP  
Avionics master switch ..... ON  
Radio equipment & transponder ..... ON/SET  
Flight instruments ..... SET & CHECKED  
Parking brake ..... RELEASE

## DURING TAXIING

Brakes ..... CHECK  
Instruments ..... (outside parking area) CHECK

## ENGINE RUNUP

Throttle ..... 1000 RPM  
Parking brake ..... SET  
Check behind ..... CLEAR  
Throttle (check outside and feet on brakes) ..... 1700 RPM  
Engine instruments ..... CHECK  
Carburetor heat ..... (check RPM drop) ON  
Carburetor heat... (RPM back to 1700 to check for carb ice) OFF  
Magnetos ..... (drop 125 RPM, diff. 50) R / BOTH / L / BOTH  
Ammeter ..... CHARGING (+)  
Throttle idle ..... ±700 RPM  
Throttle ..... 1000 RPM  
Throttle friction ..... SET

## BEFORE TAKEOFF

Flight controls ..... CHECKED  
Rudder & elevator trim ..... SET FOR TAKEOFF  
Flaps ..... (Grass, 10°) SET FOR TAKEOFF  
Transponder ..... ALT  
Landing light ..... ON  
Takeoff briefing ..... COMPLETED  
Parking brake ..... RELEASE

## AFTER TAKEOFF (Above 200ft AAL)

Flaps ..... UP  
Landing light ..... OFF

## APPROACH

Approach briefing ..... COMPLETED  
Altimeter ..... SET QNH  
Primer ..... CLOSED AND LOCKED  
Magnetos ..... BOTH  
Landing light ..... ON  
Mixture ..... RICH  
Fuel selector ..... BOTH  
Brakes ..... CHECKED  
Seat belts ..... FASTENED  
Loose Items ..... STOWED

## DOWNWIND (80-75 kts)

Carburetor heat ..... ON  
Flaps ..... (<85 kts) 10°  
Engine instruments/fuel quantity ..... CHECKED

## BASE LEG (70 kts)

Flaps ..... 20°

## FINAL (70 - 60 kts)

Flaps ..... AS REQUIRED

## BALKED LANDING

Throttle ..... FULL  
Carburetor heat ..... COLD  
Flaps ..... 20°  
Speed ..... MIN 55 kts

## AFTER LANDING (stop the aircraft clear of runway)

Flaps ..... UP  
Carburetor heat ..... OFF  
Landing light ..... OFF

## AFTER PARKING

Throttle ..... 1000 RPM  
Parking brake ..... SET  
Avionics master switch ..... OFF  
All electrical switches (Except Beacon Light) ..... OFF  
Mixture ..... IDLE CUT OFF  
Beacon light (after prop is stopped) ..... OFF  
Ignition ..... OFF AND KEY REMOVED  
Master switch ..... OFF  
HOBBS & VUT ..... NOTED  
Emergency locator transmitter ..... NOT TRIGGERED  
Gust lock & pitot cover ..... INSTALL  
Check the aircraft and windows for dirt and clean if necessary



AEROCLUB HILVERSUM-AMSTERDAM



NL-ATO-227

# ABNORMAL CHECKLISTS C-172 PH-SKC

VFR DAY  
ONLY



Perform RED & BOLD checklist items from memory

## ENGINE FAILURES:

### ENGINE FAILURE DURING TAKEOFF RUN

Throttle ..... IDLE  
Brakes ..... APPLY  
Flaps ..... RETRACT  
Mixture ..... IDLE CUT OFF  
Ignition switch ..... OFF  
Master switch ..... OFF

### ENGINE FAILURE IMMEDIATELY AFTER TAKEOFF

Airspeed ..... (flaps down) 60 kts  
..... (flaps up) 65 kts  
Mixture ..... IDLE CUT OFF  
Fuel selector valve ..... OFF  
Ignition switch ..... OFF  
Flaps ..... AS REQUIRED  
Master switch ..... OFF  
Forced landing ..... EXECUTE

### ENGINE FAILURE DURING FLIGHT

Airspeed ..... 65 kts  
Carburetor heat ..... ON  
Fuel selector valve ..... BOTH  
Mixture ..... RICH  
Ignition switch ..... (START if propeller is stopped) BOTH  
Primer ..... IN AND LOCKED  
(If engine fails to start)  
Forced landing ..... EXECUTE

## ENGINE FIRES:

### FIRES DURING START ON GROUND

Cranking ..... CONTINUE  
IF ENGINE STARTS:  
Throttle ..... 1700 RPM FOR A FEW MINUTES  
Mixture ..... IDLE CUT OFF  
IF ENGINE FAILS TO START:  
Throttle ..... FULL OPEN  
Mixture ..... IDLE CUT OFF  
Cranking ..... CONTINUE FOR 2 TO 3 MINS  
Engine ..... SECURE:  
Master switch ..... OFF  
Ignition switch ..... OFF  
Fuel selector valve ..... OFF

### ENGINE FIRE IN FLIGHT

Mixture ..... IDLE CUT OFF  
Fuel selector valve ..... OFF  
Master switch ..... OFF  
Cabin heat and air ..... (except overhead vents) OFF  
Airspeed ..... 100 kts  
(if fire is not extinguished, increase glide speed to find an  
airspeed which will provide an incombustible mixture)  
Forced landing ..... EXECUTE

## ELECTRICAL FIRE IN FLIGHT

Master switch ..... OFF  
Avionics power switch ..... OFF  
All other switches (except ignition) ..... OFF  
Vents/cabin air/heat ..... CLOSED

if fire appears out and electrical power is necessary for  
continuance for flight

Master switch ..... ON  
Circuit breakers ..... CHECK

for faulty circuit, do not reset

Radio switches ..... OFF  
Avionics power switch ..... ON  
Radio/electrical switches ..... ON

one at a time, with delay after each until short circuit  
is localized

Vents/cabin air/heat ..... OPEN  
when it is ascertained that fire is completely extinguished

## CABIN FIRE

Master switch ..... OFF  
Vents/cabin air/heat ..... CLOSED  
Land ..... AS SOON AS POSSIBLE

## ELECTRICAL POWER SUPPLY SYSTEM MALFUNCTIONS:

### AMMETER SHOWS DISCHARGE (during flight)

Alternator ..... OFF  
Non-essential radio/electrical equipment ..... OFF  
Land ..... AS SOON AS PRACTICAL

### OVER VOLTAGE LIGHT ILLUMINATES

Avionics power switch ..... OFF  
Master switch ..... (both sides) OFF  
Master switch ..... ON  
Over voltage light ..... CHECK OFF  
Avionics power switch ..... ON

### IF OVER VOLTAGE LIGHT ILLUMINATES AGAIN:

Land ..... AS SOON AS POSSIBLE

## NOTE:

*This checklist is a Recommended Operator Checklist and for  
reference only. It is not a substitute for and does not supersede  
the current approved Airplane Flight Manual.*

*For a comprehensive listing see the Airplane Flight Manual.*

## Departure and approach briefing & threat and error management

Operational briefings such as the departure and approach briefing are an integral element of the Treat and Error Management process for each flight. Briefings should focus on the identification of threats that affect the intended operations and how to mitigate those identified threats.

Furthermore, a briefing serves as mental preparation for the upcoming flight and to share with the other people on board a mental model of the intended operation.

A briefing creates capacity in thinking and acting, it enables team confidence building (e.g. when you fly with another rated pilot) and minimizes the startle effect when non-standard situations are encountered. This increases resilience.

### Threats

All of the following are threats:

- Events or errors that occur beyond the influence of the flight crew
- Increased operational complexity
- Situations that must be managed to maintain the margin of safety.

There is no limit to the possible number of threats that may occur. Examples of possible threats are:

Airport	ATC	Aircraft	Environment
<ul style="list-style-type: none"> <li>- Infrastructure</li> <li>- Runway condition</li> <li>- NOTAMs</li> </ul>	<ul style="list-style-type: none"> <li>- Restrictions</li> <li>- Phraseologies</li> <li>- Required reporting points</li> </ul>	<ul style="list-style-type: none"> <li>- Aircraft defects</li> <li>- Fuel status</li> </ul>	<ul style="list-style-type: none"> <li>- Tree tops</li> <li>- Buildup areas to avoid</li> <li>- Glider activity</li> <li>- Noise abatement area's</li> </ul>
Weather	Crew	Terrain	
<ul style="list-style-type: none"> <li>- Wind direction, gusts</li> <li>- Visibility</li> <li>- Sunrise/sunset visibility</li> </ul>	<ul style="list-style-type: none"> <li>- Who is PF/PIC</li> <li>- Low experience</li> <li>- Distraction of passengers</li> </ul>	<ul style="list-style-type: none"> <li>- Unfamiliar environment</li> <li>- Specific visual dep/arr routes</li> </ul>	

### Preparation for briefing:

Preparation for each briefing starts with the preparation for the flight by collecting the data for your flight such as aircraft technical status, route planning, weather, NOTAMs and fuel planning. Once ready to brief, which can be done after the walkaround once settled in the seat before starting the checklists, the suggested briefing structure is:

### Plan, threats, threat management, miscellaneous

Suggested items of a departure briefing are:

#### PLAN

- Takeoff runway and how to get there
- Wind direction
- Type of takeoff (normal, short field, soft field etc.)
- First altitude and where to go after takeoff
- Available (extra) fuel
- What to do in case of rejected takeoff
- What to do in case of engine failure after takeoff

- Who is PF, who is PIC
- Who does what when flying with 2 rated pilots

## THREATS

- Brief any threats (see examples in matrix above)

## THREAT MANAGEMENT

- Brief what you can do to mitigate the mentioned threats

## Miscellaneous

- E.g. pax briefing if not already briefed (e.g. request to remain silent till after departure)

An example of a departure briefing is:

### PLAN

- Runway 25 in use
- Wind direction 230/10
- From here 2 times right and then to the beginning of the runway for engine checks
- We are going to make a soft field takeoff (and if necessary, explain how)
- We leave the circuit at 700 ft at the crosswind leg under 45 degrees
- We have  $\frac{3}{4}$  tank so one-hour extra fuel on top of minimum required
- In case we reject. (explain actions with touch check)
- In case of failure after takeoff, available fields are limited in takeoff direction so if needed we turn 90 degrees to the left
- I am PF, you are PIC (e.g. in case of flying with instructor)
- Who does what when flying with 2 rated pilots (I fly the airplane; you do the RT and back me up where required).

## THREATS AND THREAT MANAGEMENT

- Gliders active so in case of go around, we stay clear of the right side of the runway)
- Sun is low, so sunglasses on and if necessary, we ask the havenmeester for the strobe lights on
- What other threats do you see? (if flying with another rated pilot or instructor)

## MISCELLANEOUS

- Passengers, please stay silent until I give a sign, somewhere after leaving the circuit

The same briefing structure can be used for the approach briefing with the following suggested items:

### PLAN

- Landing runway and pattern
- Wind direction
- How to approach the field
- Available fuel
- Type of landing (normal, short field, flapless, touch and go)
- Where to leave the runway and where to go next

## THREATS

- Brief any threats (see examples in matrix above)

## THREAT MANAGEMENT

- Brief what you can do to mitigate the mentioned threats

## MISCELLANEOUS

- E.g. pax briefing (e.g. request to remain silent)

An example of an arrival briefing is:

### PLAN

- Landing runway 25 left hand pattern
- Wind 230/10
- I approach the field by flying around St. Maartensdijk while descending to 700 ft and aim to arrive perpendicular to the downwind track.
- Available fuel is 1/4 tank, so we have to land within 30 minutes
- For practice I make a flapless landing so downwind/base/final speeds are X/Y/Z kts.
- After landing we leave the runway on the lefthand side and stop to do the after-landing checklist, then we taxi to the fuel pump

## THREATS AND THREAT MANAGEMENT

- Gliders active so in case of go-around, we stay clear of the right side of the runway
- Grass is still wet so careful on the brakes to prevent slipping
- What other threats do you see? (if flying with another rated pilot or instructor)

## MISCELLANEOUS

- Passengers, please stay silent from now on, until we have stopped after landing

## Radio telephony examples

### Before departing: EHTE

PH-ABC : "Teuge radio, PH-ABC." \*

EHTE : "PH-ABC, Teuge radio."

PH-ABC : "PH-ABC, C172, parked on the apron, local training flight, 2 pob."

EHTE : "PH-ABC, runway 26, left hand circuit."

PH-ABC : "Runway 26, lefthand circuit, PH-ABC."

PH-ABC : "PH-ABC, lining up runway 26."

PH-ABC : "PH-ABC, leaving the circuit."

PH-ABC : "PH-ABC, changing frequency to Dutch Mil info."

\* Note: For departure at EHHV first call is a radio check and no aerodrome information is requested since a visit to the 'havendienst' is mandatory before departure to inform yourself about the departure information.

### Initial call Dutch Mil Info/Amsterdam Information: (132.350, 124.300)

PH-ABC : "Amsterdam information, PH-ABC." or "Dutch Mil Info, overhead *position* (e.g. Soest).";  
source: AIP

Dutch Mil Info : "PBC \*, Dutch Mil Info."

PH-ABC: : "PBC, C172, *position* (e.g. 3 nm south of Hilversum), *altitude* (e.g. 1500 ft),  
VFR EHHV-EHHV, Training Flight, 2 POB."

Dutch Mil Info : "PBC, QNH 1020, no reported traffic at *altitude* (e.g. 1500 ft)."

PH-ABC : "QNH 1020, PBC."

\* Note: The standard protocol requires an aircraft to always use its full call sign during initial contact with an ATS (Air Traffic Services) unit. The ground station (the "owner of the frequency") is the only entity permitted to initiate the abbreviation. Once ATC has shortened your identifier (e.g., from Papa Hotel Alpha Bravo Charly to Papa Bravo Charly), the pilot is required to use the abbreviated call sign in all subsequent transmissions.

### Initial call tower controlled airport:

PH-ABC : "Eelde tower, PH-ABC."

EHGG TOWER : "PH-ABC, Eelde Tower."

PH-ABC : "PH-ABC, C172, *position* (e.g. Assen), *altitude* (e.g. 1500 ft), VFR, information ATIS (e.g. A), for landing."

EHGG TOWER : "PH-ABC, Roger, *arrival* (e.g. Romeo), runway 23, QNH 1020."

PH-ABC : "*arrival* (e.g. Romeo), runway 23, QNH 1020, PH-ABC."

### Arrival at EHHV

PH-ABC : "Hilversum radio, PH-ABC."

EHHV : "PH-ABC, Hilversum radio."

PH-ABC : "PH-ABC, C172, VFR from *departure airport* (e.g. Lelystad), at *position* (e.g. 10 nm south of Hilversum), *altitude* (e.g. 1500 ft), request aerodrome information."

EHHV : "PH-ABC, runway 25, left hand circuit, (gilders ....., paras .....)."

PH-ABC : "Runway 25, lefthand circuit, PH-ABC."

PH-ABC : "PH-ABC, entering lefthand downwind runway 25."

PH-ABC : "PH-ABC, turning base." (optional)

PH-ABC : "PH-ABC, final runway 25, (full stop or touch and go)."

### Changing Frequency from Amsterdam Information/ Dutch Mil Info to Hilversum Radio

PH-ABC : "PH-ABC, overhead *position* (e.g. Zeist), changing frequency to Hilversum radio."

Dutch Mil : "PH-ABC, Roger."

### Changing Frequency from Dutch Mil to Amsterdam information (FIC)

PH-ABC : "PH-ABC, overhead *position* (e.g. Woerden), changing frequency to Amsterdam Information."

Dutch Mil : "PH-ABC, Roger."

### Excerpt of EHHV AIP to be noticed by pilots

For glide-ins from 1000 FT downwind the following applies:

- Mandatory call;
- No other traffic ahead in the circuit;
- With instructor only.

Recommended calls:

- Initial call and position;
- Report (joining) downwind RWY NR;
- Report final RWY NR and intention.

---

For increased situational awareness of other traffic in the circuit and near the aerodrome, the following is recommended:

- Helicopters use call sign with prefix HELI;
- Gyrocopters use call sign with prefix GYROCOPTER;
- Gliders use call sign with prefix GLIDER;
- Student pilots flying solo use call sign with prefix STUDENT.

## General Aircraft Information

### Cockpit layout (PH-DON)



#### 1 Flight Instruments

Airspeed indicator  
 Attitude indicator (Garmin G5)  
 Altitude indicator  
 Turn and bank indicator  
 Directional gyro indicator (Garmin G5)  
 Vertical speed indicator  
 Magnetic compass

#### 2 Navigation Indicators

VOR/ILS indicator  
 VOR indicator  
 ADF bearing indicator

#### 3 Radio Stack

Audio control panel  
 NAV / COM 1  
 NAV / COM 2  
 DME  
 ADF radio  
 Transponder

#### 4 Engine Instruments

Tachometer (not visible)  
 Oil temperature and pressure  
 Fuel quantity indicators  
 EGT, exhaust gas temperature  
 CHT, cylinder head temperature

#### 5 Engine Controls

Mixture control (red)  
 Throttle (power)  
 Carburetor heat  
 Fuel selector valve handle  
 Primer  
 Ignition switch

#### 6 Flight Controls

Control column  
 Rudder control  
 Elevator trim  
 Rudder trim  
 Flaps (electrical)

#### 7 Electrical

Magnetos  
 Master switch  
 Ammeter  
 Avionics master switch  
 Landing lights  
 Strobe lights  
 ELT, emergency locator  
 Transmitter switch  
 Pitot head  
 Fuses  
 Headset connection  
 External mic

#### 8 Others

Hobb's  
 VUT  
 Parking brake  
 Cabin air

## General information

<b>Speeds</b>	<b>V<sub>speeds</sub></b>	<b>PH-SKC</b>	<b>PH-JBC</b>	<b>PH-DON</b>
Stall speed flaps up	V <sub>S1</sub>	44 kts	49 kts	44 kts
Stall speed flaps down	V <sub>SO</sub>	33 kts	42 kts	33 kts
Maneuvering speed	V <sub>A</sub>	97 kts	97 kts	99 kts
Max speed flaps extended: 10°	V <sub>FE</sub>	85 kts	87 kts	110 kts
Max speed flaps extended: 10°- 30°	V <sub>FE</sub>	--	--	85 kts
Never exceed speed	V <sub>NE</sub>	160 kts	158 kts	158 kts
Max structural cruising speed	V <sub>NO</sub>	128 kts	126 kts	127 kts
Best rate of climb (sea level) speed	V <sub>Y</sub>	73 kts	70 kts	76 kts
Best angle of climb, (sea level) speed	V <sub>X</sub>	60 kts	60 kts	60 kts
Max demonstrated cross wind	--	15 kts	15 kts	15 kts
Max takeoff cross wind	--	--	20 kts	--
Best glide speed flaps up	V <sub>BG</sub>	65 kts	70 kts	65 kts
Best glide speed flaps down	V <sub>BG</sub>	60 kts	65 kts	60 kts
<b>Weights</b>		<b>PH-SKC</b>	<b>PH-JBC</b>	<b>PH-DON</b>
Empty weight (Note: Check actual weighing rapport)		691.3 Kg	670,5 Kg	694.3 Kg
Max fuel in kg		136.1 Kg	103.4 Kg	108.9 Kg
Max fuel in litres		189 L	143.6 L	151.2 L
Maximum baggage in baggage - 1		54 Kg	54 Kg	54 Kg
Maximum baggage in baggage - 2		23 Kg	23 Kg	23 Kg
Max T/O normal category		1089 Kg	1043 Kg	1089 Kg
Utility category		952.5 Kg	907.1 Kg	955.7 Kg
<b>Average fuel consumption</b>		<b>PH-SKC</b>	<b>PH-JBC</b>	<b>PH-DON</b>
Tank capacity (unusable)	USG   l	4   15,1	4   15.1	3   11.4
Tank capacity (usable)	USG   l	50   189	38   144	40   151
2300 RPM cruise 60%	USG   l/hr	±6,7   25.4	±6,7   25.4	±6,7   25.4
2500 RPM climb 72%	USG   l/hr	±7.8   29.5	±7.8   29.5	±7.8   29.5
Full power gallon / Hr	USG   l/hr	±9.7   36,7	±9.7   36,7	±9.7   36,7
<b>G Loads</b>				
Maximum G-load – flaps up	normal category		-1,52G	+3,8G
	utility category		-1,76G	+4,4G
	with (any) Flaps		-0,00G	+3,0G

Note: For Mass & Balance and other calculations, always use the approved AFM. And check the ACHA website for the most recent aircraft numbers.

## Power setting / configuration versus speed table

	throttle(RPM)	flaps	speed
Climb	full throttle	10°	70 kts
Climb	full throttle	UP	V <sub>Y</sub> or 80 kts
Cruise	±2300RPM	UP	100 kts
Descent	±1800RPM	UP	100 kts
Downwind	±1900RPM	UP	80 kts
Downwind	±1900RPM	10°	75 kts
Base	±1500RPM	20°	70 kts
Final	as required	30°	70-60 kts

### Note:

- Power settings in ISA atmosphere and depending on weight.
- Carburetor heat ON when power setting below 2000 RPM.

### Fuel and Oil

Approved fuel: 100LL (blue) AVGAS. Approved oil: refer to the current POH/AFM for each aircraft for the approved oil type and grade. Always verify fuel and oil specifications in the applicable POH/AFM before flight.

## Normal procedures

### General advice

### Cockpit practical advice

- Ensure the same seat position on every flight. This implies that you have the same reference sight picture on every flight and that you can predictably reproduce the aircraft attitude during climb, descend, banking etc.
- Use of checklist: Ensure that each item is checked by keeping the checklist in one hand with the thumb by last item.

### Instruments / brakes check during taxiing

When commencing taxiing at the beginning of a flight, the brakes shall be checked, and proper functioning of the turn/slip indicator, heading/track indicator (G5), attitude indicator (G5) and compass shall be checked and called out loud after leaving the parking area and preferably in the natural turns to the t/o runway

### Taxiing with different wind directions

Figure 1 – Taxiing with different wind directions. (taxiing diagram)

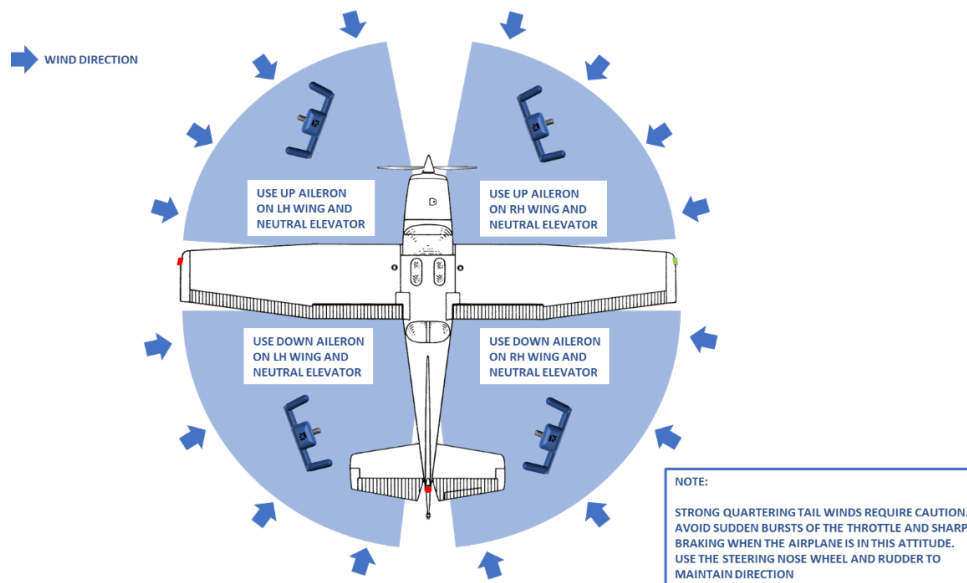

## Reporting other aircraft

During the scanflow (lookout) you may see other airplane traffic. Report this directly by saying: “Traffic, 9 o’ clock, just above the horizon”. Use the clock method combined with above, below or on the horizon.

Figure 2 – Clock method

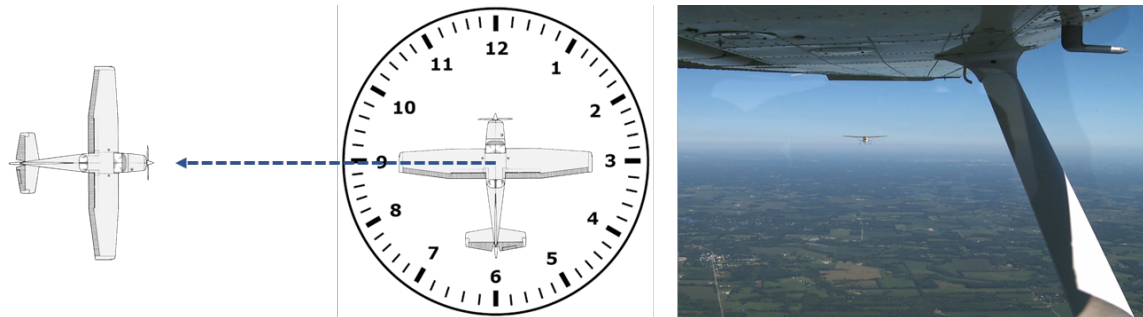

“Traffic, 9 O’clock, just above the horizon”

## Structured scanflow

- Scanflow for straight and level flight (side to side scanning method and front to side scanning method)
- Scan in sectors (see Figure 3a and 3b)
- Check nose attitude
- Short inside scan (altitude, speed, skid indicator)
- Approx. every 15 min, engine instruments and fuel quantity

## Side to side scanning method

Start at the far left of your visual area and make a methodical sweep to the right, pausing very briefly in each block of the viewing area to focus your eyes. At the end of the scan, return to and scan the instrument panel and then repeat the external scan.

Figure 3a – Structured lookout side to side scanning technique



## Front to side scanning method

Start in the center block of your visual field (center of front windshield); move to the left, focusing very briefly in each block, then swing quickly back to the center block after reaching the last block on the left and repeat the action to the right. Then, after scanning the instrument panel, repeat the external scan.

Figure 3b — Structured lookout front to side scanning technique

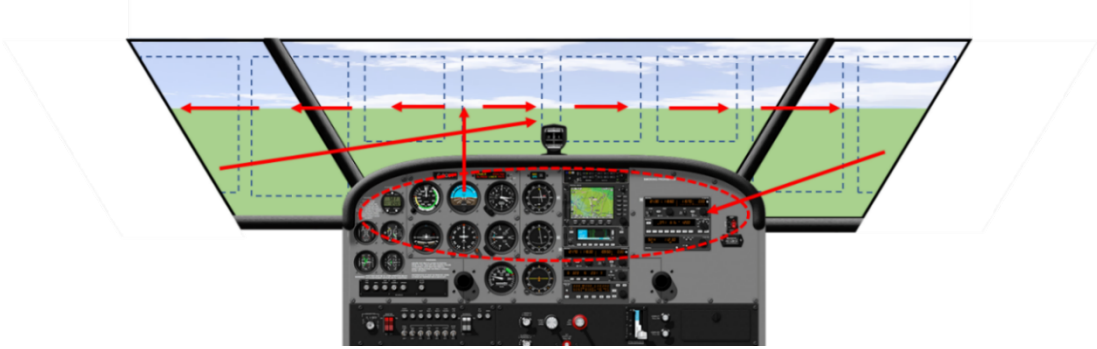

## Manoeuvres

### Clearing turns before manoeuvres with reduced controllability

- Check:
  - ✓ Engine instruments
  - ✓ Take a point in the distance (**PITD**)
- First make a left turn:
  - ✓ Check right for traffic above
  - ✓ Check in front for other traffic
  - ✓ Check left for other traffic below
- Roll out:
  - ✓ Check left, front and right for other traffic
- Make a subsequent right turn:
  - ✓ Check left for other traffic above
  - ✓ Check in front for other
  - ✓ Check right for other traffic below
- Roll out:
  - ✓ Check left, front and right for other traffic
- Keep scanning and regularly check:
  - ✓ Nose attitude
  - ✓ Altitude (constant)
  - ✓ Speed (90 kts)
  - ✓ Coordinated flight (ball centered, wings horizontal)
  - ✓ Proceed with planned maneuver

Figure 4 – Clearing Turns for every maneuver

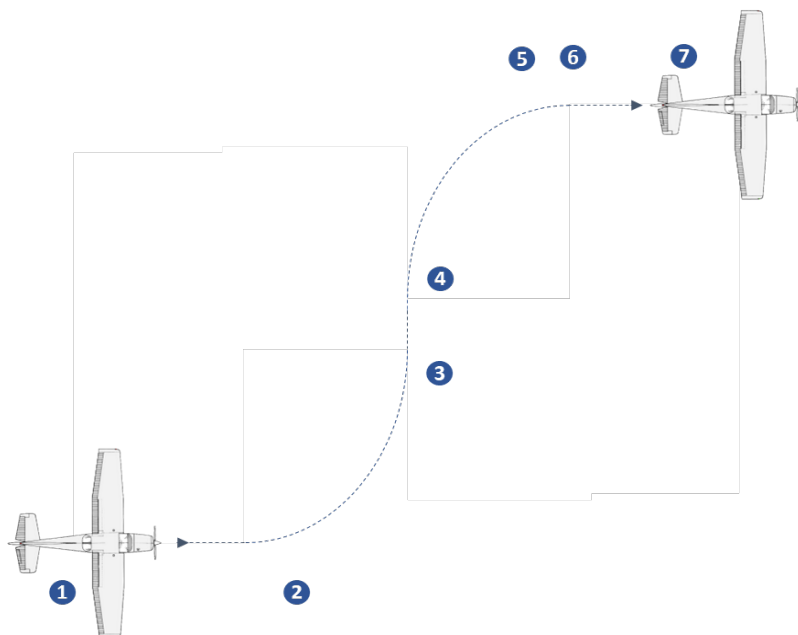

## Straight and level flight

- (1) Look out for traffic
- (2) Set nose attitude for straight and level flight (glare shield approx. 4 fingers below horizon)
- (3) Maintain wings level
- (4) Keep direction with rudder (ball centered)
- (5) Power setting 2300 RPM
- (6) Airspeed 100 kts
- (7) Trim off forces
  - Maintain lookout and regularly check:
  - Nose attitude
  - Altitude (constant)
  - Airspeed (100 kts)
  - Coordinated flight (ball centered)

Figure 5a – Straight and level flight



Figure 5b – Straight and level flight



## Transition from straight and level flight to climb

- (1) Check engine instruments (and thereafter every 1000 ft)
- (2) Look out for traffic
- (3) Raise nose to climb attitude
- (4) Speed decreases
- (5) Airspeed approaches 80 kts, smoothly advance throttle FULL (Do not exceed maximum RPM. Check RPM after advancing to full throttle and reduce if necessary.)
- (6) Maintain wings level, coordinated rudder, PITD
- (7) Trim off forces
- (8) Perform clearing turns every 500ft (15° bank angle, 30° left and right off course) or lower nose for lookout

Figure 6 – Transition from straight and level flight to Climb

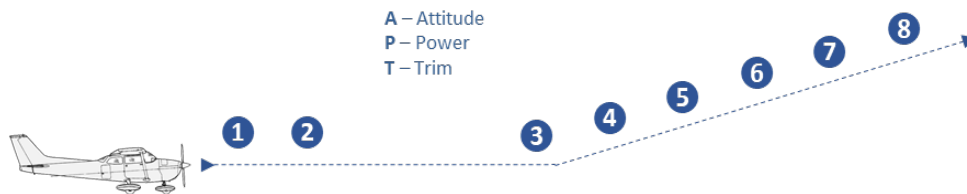

## Transition from climb to straight and level flight

- (1) Look out for traffic
- (2) 20ft before desired altitude, slowly lower nose to straight and level attitude with 100 kts.
- (3) Airspeed accelerates to 100 kts
- (4) Reduce throttle to 2300 RPM
- (5) Maintain wings level, coordinated rudder, PITD
- (6) Trim off forces

Figure 7 – Transition from Climb to Straight and Level Flight

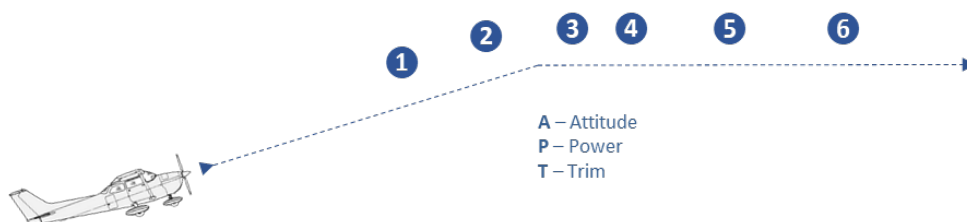

## Transition from straight level flight to descending flight

- (1) Check engine instruments
- (2) Carburetor heat ON
- (3) Look out for traffic
- (4) Throttle 1800 RPM (every 100 RPM equals  $\pm 100$  ft/min extra descent rate)
- (5) Simultaneously lower nose to descent attitude, maintain 100 kts
- (6) Maintain wings level, coordinated rudder, PITD
- (7) Trim off forces

Figure 8 – Transition from straight level flight to descending flight



## Transition from descent to straight and level flight

- (1) Look out for traffic
- (2) 100ft before desired altitude – carburetor heat OFF
- (3) 50 ft before desired altitude – increase throttle to  $\pm 2300$  RPM
- (4) Raise nose to straight and level flight attitude
- (5) Airspeed 100 kts
- (6) Maintain wings level, coordinated rudder, PITD
- (7) Trim off forces

Figure 9 – Transition descent to straight and level flight

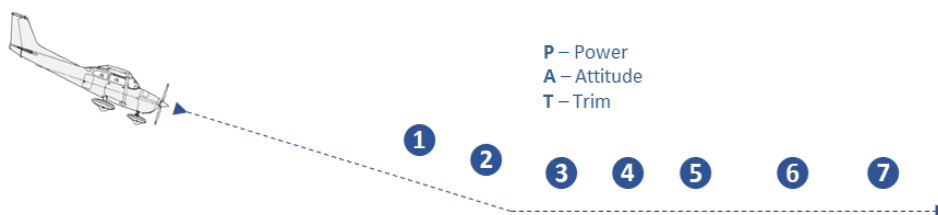

## Transition from straight and level to glide

- (1) Check engine instruments
- (2) Carburetor heat ON
- (3) Look out for traffic
- (4) Smoothly retard throttle to idle
- (5) Maintain altitude by slowly raising nose attitude
- (6) Airspeed approaches 65 kts, lower nose to glide attitude
- (7) Maintain wings level, coordinated rudder, PITD
- (8) Trim off forces

Figure 10 – Transition from straight and level to glide

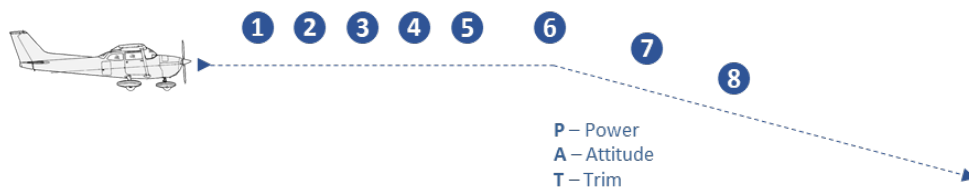

## Clearing the engine during glide

- (1) Check engine instruments
- (2) Look out for traffic
- (3) Smoothly advance throttle full forward
- (4) Simultaneously raise nose to climb attitude, maintain 65 kts
- (5) After 3-5 sec smoothly close throttle, lower nose to glide attitude with 65 kts, maintain wings level, coordinated rudder, PITD
- (6) Continue with glide

Figure 11 – Clearing the engine during glide

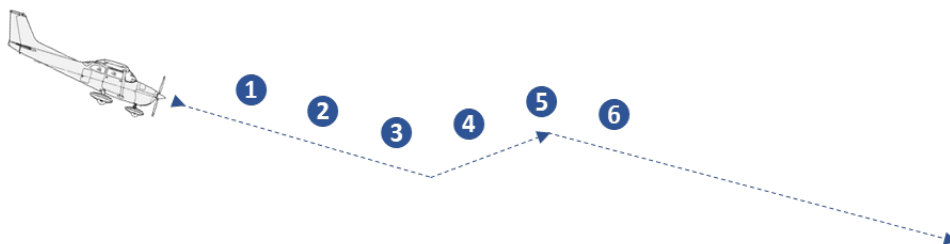

## Transition from glide to straight and level flight

- (1) Look out for traffic
- (2) 150ft before desired altitude, advance throttle to  $\pm 2300$  RPM, carburetor heat OFF
- (3) Maintain glide attitude, airspeed increases
- (4) 50ft before desired altitude, raise nose to straight and level flight attitude
- (5) Airspeed 100 kts
- (6) Maintain wings level, coordinated rudder, PITD
- (7) Trim off forces

Figure 12 – Transition from glide to straight and level flight

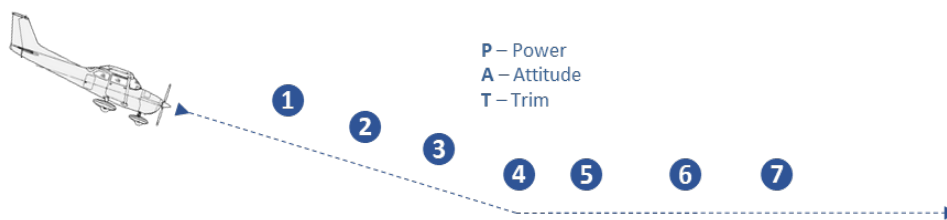

## Level turn

- (1) Look out for traffic and take a PITD
- (2) Roll into turn, 30° bank angle, coordinated rudder and;
- (3) Increase backpressure and set nose attitude to maintain altitude
- (4) Keep scanning for traffic and check:
  - Bank angle 30°
  - Nose attitude
  - Instruments: altitude indicator, vertical speed indicator and airspeed, slip indicator
- (5) 10° before desired heading or PITD start to roll wings level, coordinated rudder and;
- (6) Decrease backpressure to maintain altitude
- (7) Maintain wings level, coordinated rudder, PITD, 100 kts

Figure 13 – Horizontal turn

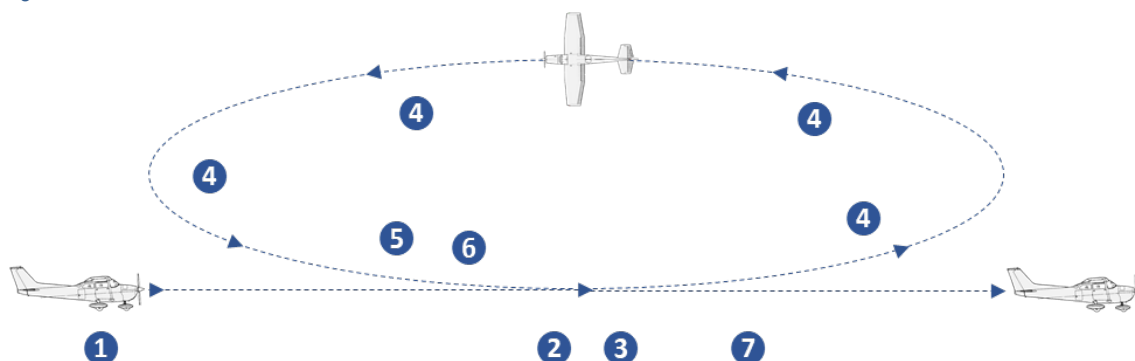

## Climbing turn

- (1) Look out for traffic
- (2) Roll into turn max 15° bank angle
- (3) Coordinated rudder
- (4) Keep scanning and check:
  - Bank angle 15°
  - Nose attitude
  - Instruments: approaching altitude, airspeed 80 kts, slip indicator
- (5) 5° before desired course or PITD, start to roll wings level
- (6) Coordinated rudder
- (7) Maintain wings level, coordinated rudder, PITD, airspeed 80 kts

Figure 14 – Climbing turn

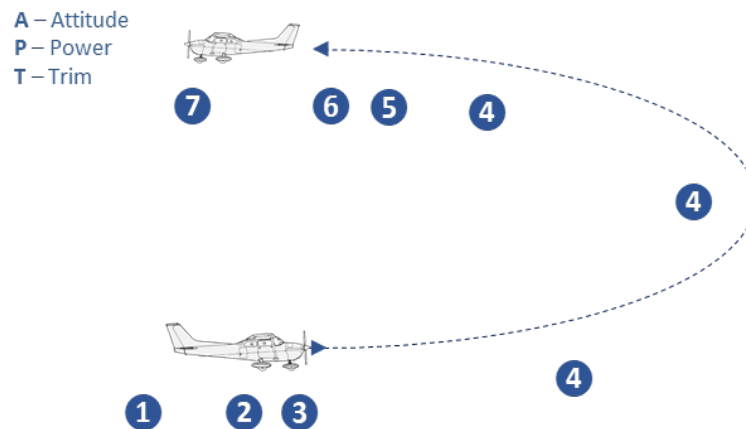

## Descending turn

- (1) Look out for traffic
- (2) Roll into turn, 30° bank angle
- (3) Coordinated rudder
- (4) Keep scanning for traffic and check:
  - Bank angle 30°
  - Nose attitude
  - Instruments: approaching altitude, airspeed 100 kts, slip indicator
- (5) 10° before desired course or PITD start to roll wings level
- (6) Coordinated rudder
- (7) Maintain wings level, coordinated rudder, PITD, airspeed 100 kts

Figure 15 – Descending turn

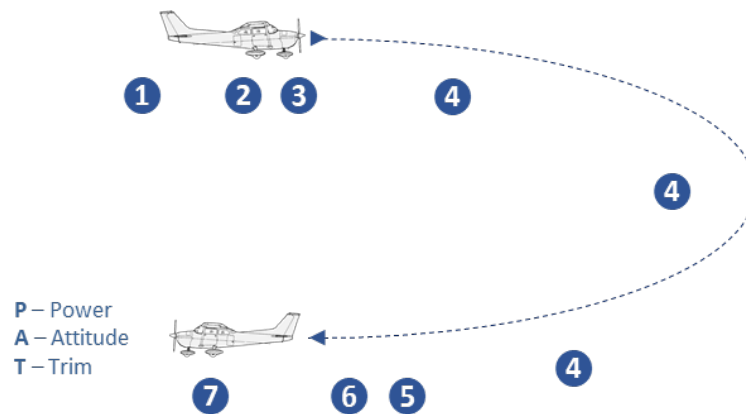

## Steep turn (45°)

- (1) Check engine instruments
- (2) Look out for traffic and take a PITD
- (3) Roll into turn, 45° bank angle, coordinated rudder
- (4) When bank angle passes 30°, increase RPM by 200 and;
- (5) Increase backpressure and set nose attitude to maintain altitude
- (6) During the turn keep scanning for traffic and check:
  - Bank angle 45°
  - Nose attitude
  - Instruments: altitude indicator, vertical speed indicator and airspeed 100 kts
- (7) 20° before desired course or PITD start to roll wings level, coordinated rudder
- (8) When bank angle passes 30° decrease RPM by 200 and;
- (9) Decrease back pressure to maintain altitude and set nose attitude to straight and level flight
- (10) Maintain wings level, coordinated rudder, PITD, 100 kts

Figure 16a – Steep turn with constant height and airspeed

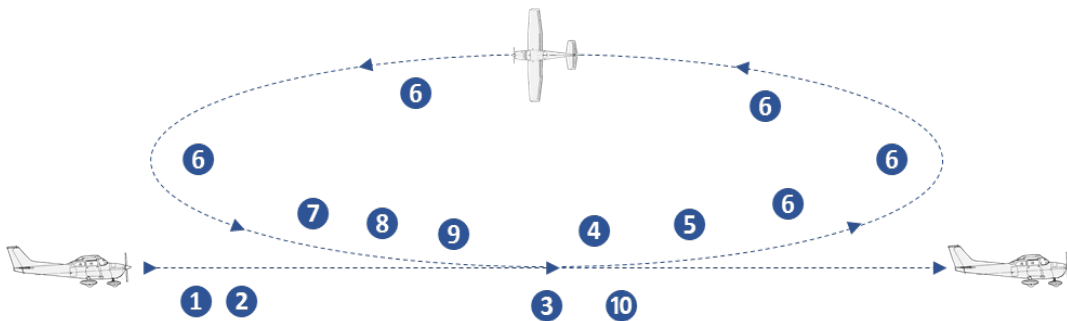

**NOTE:** Minimum altitude for this exercise is 1500 ft AGL Dual / 2000 ft AGL solo

Figure 16b – Steep turn – Pilot View (depending on seat position)



Left and right turn



Left and right turn

## Slow flight Vs + 10

**NOTE:** Minimum altitude for this exercise is 2000 ft AGL solo

Slow flight can be performed with flaps up or with flaps down, with speed Vs+10.

Communicate before the exercise which variant you are to perform.

- Look up beforehand the Vs with the used flap setting (see table below)
- The POH for the PH-DON gives stall speeds for flaps UP, 10° and 30°, interpolate for flaps 20°
- The POH for the PH-SKC gives stall speeds for flaps UP, 10° and 40°. However, due to the modification
- The max flap setting is 30°, use stall speeds as given in the AFM, interpolate for flaps 20°.
- Max bank angle 15° during exercise due to margin to stall

### Exercise slow flight

- Check engine instruments
- Carburetor heat ON
- Look out for traffic
- Reduce throttle to 1500 RPM
- Maintain altitude by slowly raising nose, airspeed decreases
- Set flaps as required
  - When using flaps, check speed to be in the white arc, acknowledge with call-out “Speed checked”, then lower the flaps in steps to planned setting. Manage the ballooning effect.
- As airspeed approaches planned speed, advance throttle to ± 2200 RPM
- Respect the stall warning: increase speed enough to stop stall warning if warning comes on
- Maintain wings level, coordinated rudder
- Trim off forces
- Keep scanning for traffic and check:
  - Nose attitude
  - Coordinated rudder, PITD
  - Airspeed Vs+10 kts

	V <sub>speeds</sub>	PH-SKC	PH-DON	PH-JBC
Stall Speed Flaps Up	V <sub>S1</sub>	44 kts	44 kts	49 kts
Stall Speed Flaps 10°	V <sub>S1</sub>	37 kts	37 kts	47 kts
Stall speed Flaps 20°	V <sub>S1</sub>	35 kts	35 kts	44 kts
Stall Speed Flaps 30°	V <sub>SO</sub>	33 kts	33 kts	42 kts

### Accelerate to 100 kts

- Smoothly advance throttle full forward
- Carburetor heat OFF
- Maintain wings level, coordinated rudder, PITD
- When speed above 60 kts, check speed to be in the white arc and call out: “Speed checked” and raise flaps in steps before speed increases above white arc
- Lower nose as speed increases, maintain altitude
- Speed 100 kts, throttle 2300 RPM
- Trim off forces

---

## Air Exercises

### The stall

#### Planning, crew briefing and checks before the stall

The main purpose of the stall exercise is to teach the student to recognize the symptoms of an approaching stall so as to avoid getting into a stall. The second goal is to, in the event that an actual stall occurs, be able to recover the airplane to normal flight. Because the airplane has limited maneuverability during this exercise, extra precautions have to be taken before starting the exercise.

**NOTE:** Make a plan first to ensure a safe execution of the maneuver.

Priority shall be given to recovery from the stall (decrease angle of attack) and not altitude loss!

#### Crew briefing:

- Type of stall
- Altitude (AGL) and heading/course during the maneuver
- When the recovery starts and in what manner

#### Inside checks:

- |                          |   |
|--------------------------|---|
| ✓ Ignition               | BOTH                                    |
| ✓ Landing light          | ON                                      |
| ✓ Throttle               | 2300 RPM                                |
| ✓ Mixture                | RICH                                    |
| ✓ Flaps                  | UP                                      |
| ✓ Fuel selector          | BOTH                                    |
| ✓ Engine instruments     | (temp and pressures in the green) CHECK |
| ✓ Speed                  | 100 kts                                 |
| ✓ Belts, loose equipment | FASTENED/STOWED                         |

---

## Outside checks – APOS

### Altitude:

Full stall: recovered above 3000 ft solo or 2000 ft dual AGL

Approach to stall: recovered above 2000 ft solo or 1500 ft dual AGL

### Position:

not above:

- Open water (because lack of horizon)
- Cities or industrial areas
- Airports or CTRs
- Other traffic
- Open air assemblies of people
- 4/8 cloud cover or more

### Orientation:

- Keep track of position and airspace
- Do not fly in direction of above-mentioned points
- Take a PITD or significant line

### Sky clearing turns:

- Clearing turns 2 x 90° or;
- Clearing turn 180° (take a new PITD)

### Checks after the stall

- |  |          |
|--|----------|
| ✓ Flaps  | UP       |
| ✓ Carburetor heat  | OFF      |
| ✓ Throttle   | 2300 RPM |
| ✓ Check engine instruments (temp and pressures in the green) | CHECK    |
| ✓ Orientation  | CHECK    |

## Stall with flaps up

- Clearly state “starting the exercise”
- Carburetor heat ON, smoothly close the throttle
- Raise nose with decreasing airspeed to maintain altitude, don't trim off forces
- Maintain wings level, maintain heading with rudder, PITD
- **Start recovery in case of full stall:**
  - Nose dip (self-recovery)
  - Wing dip (initially with rudder, after the nose is lowered and stall is recovered, use ailerons)
  - High descent rate with full aft elevator; whichever comes first
- **Start recovery in case of approach to stall:**
  - Stall warning
  - Buffet
  - 5 kts above stall speed; whichever comes first

## Recovery with power

- Call out “recover” and:
- Unload to reduce angle of attack below critical angle
  - For full stall, lower nose to glide attitude
  - For approach to stall lower nose just below straight and level attitude
- Roll wings level, PITD
- Power: Smoothly advance throttle full forward, carburetor heat OFF
- At minimum 60 kts, gently raise nose to climb attitude (avoid a secondary stall)
- Maintain wings level, coordinated rudder, PITD
- Adjust nose attitude for correct climb attitude with airspeed 80 kts
- Climb back to initial altitude and transition to straight and level flight

## Recovery without power

- Call out “recover” and:
- Unload to reduce angle of attack below critical angle
- Roll wings level PITD
- Adjust nose to attitude for glide, 65 kts
- Trim off forces
- Transition to straight and level flight at desired altitude (see transition from glide to straight and level flight)

## Stall with flaps down

- Clearly state “starting the exercise”
- Smoothly close the throttle, carburetor heat ON
- Maintain wings level, coordinated rudder, PITD
- Nose attitude increases with decreasing airspeed, maintain altitude, don't trim off forces
- Maintain wings level, coordinated rudder, PITD
- As soon as airspeed is in white arc call out: “Speed checked” and lower flaps in steps
- Watch out for ballooning, maintain altitude
- **Start recovery in case off full stall:**
  - Nose dip (self recovery)
  - Wing dip (initially with rudder, after the nose is lowered and stall is recovered, use ailerons)
  - High descent rate with full aft elevator; Whichever comes first
- **Start recovery in case off approach to stall:**
  - Stall warning
  - Buffet
  - 5 kts above stall speed; Whichever comes first

## Recovery with power from stall with flaps

- Call out “recover” and:
  - Unload to reduce angle of attack below critical angle
  - For full stall, lower nose to glide attitude
  - For approach to stall lower nose just below straight and level attitude
- Roll wings level, PITD
- Power: Smoothly advance throttle full forward, carburetor heat OFF
- At minimum 60 kts, gently raise nose to climb attitude (avoid a secondary stall)
- Call out: “Speed checked” and Select flaps 10°
- Adjust nose to correct climb attitude flight with 65 kts
- Call out: “Speed checked” and select flaps UP, accelerate to 80 kts
- Climb back to initial altitude and transition to straight and level flight

## Approach to stall in descending turn in approach or landing configuration

- Clearly state “starting the exercise”
- Carburetor heat ON, reduce throttle to 1500 RPM
- Maintain wings level, coordinated rudder, PITD
- Maintain altitude, nose attitude increases with decreasing speed, don't trim off forces
- Airspeed in white arc, call out: “Speed checked” and select flaps in stages to 20° (for approach) or 30° (for landing)
- Lower the nose and start a descending turn with 20° bank angle
- Close the throttle and slowly raise the nose
- **Start recovery on:**
  - Stall warning
  - Buffet
  - 5 kts above stall speed (whichever comes first)

## Recovery with power from approach to stall during descending turn

- Call out “recover” and:
- Unload to reduce angle of attack below critical angle
- Roll wings level, PITD
- Power: Smoothly advance throttle full forward, carburetor heat OFF
- Start the go-around procedure
- note: compared to standard go-around procedure flaps 20° are already set for recovery from approach configuration, for everything else proceed the same way as in a standard go-around

## Approach to stall in climbing turn without flaps

- Clearly state “starting the exercise”
- Raise nose to climb at 80 kts
- Reduce power to 1800 RPM and
- Start a climbing turn with 15° bank angle
- Raise the nose attitude to decelerate speed, maintain 15° bank angle
- **Start recovery on:**
  - Stall warning
  - Buffet
  - 5 kts above the stall speed without flaps (whichever comes first)

## Recovery from approach to stall in climbing turn

- Call out “recover” and:
- Unload: reduce angle of attack below critical angle
- Roll: Wings level, PITD
- Power: Smoothly advance throttle full forward
- Accelerate to 100 kts

## Approach to stall in climbing turn with flaps in takeoff configuration (Flaps 10°)

- Clearly state “starting the exercise”
- Bring the aircraft in approach configuration in level flight, speed 70kts. Airspeed in white arc, call out: “Speed checked” and select flaps 10° (for takeoff)
- Reduce power to 1800 RPM

- Start a climbing turn with 15° bank angle
- Raise the nose attitude to decelerate speed, maintain 15° bank angle
- **Start recovery on:**
  - Stall warning
  - Buffet
  - 5 kts above the stall speed without flaps (whichever comes first)

## **Recovery from approach to stall in climbing turn in takeoff configuration**

- Call out “recover” and:
  - Unload to reduce angle of attack below critical angle
  - Roll wings level, PITD
  - Power: Smoothly advance throttle full forward
  - Immediately check or select flaps 10°
  - Safe speed, minimum 55 kts, set nose just below normal climb attitude
  - Check positive rate, call out: “Speed checked” and select flaps up
  - Minimum speed 60 kts, accelerate to  $V_y$  and climb to assigned level or continue straight and level flight and accelerate to 100 kts

## Circuit procedures

### VFR circuit

With regard to safe, orderly and expeditious aerodrome traffic at uncontrolled aerodromes, rules are laid down for the standard aerodrome traffic circuit and circuit areas.:

The standard circuit looks like this:

Figure 17 – Standard lefthand circuit.

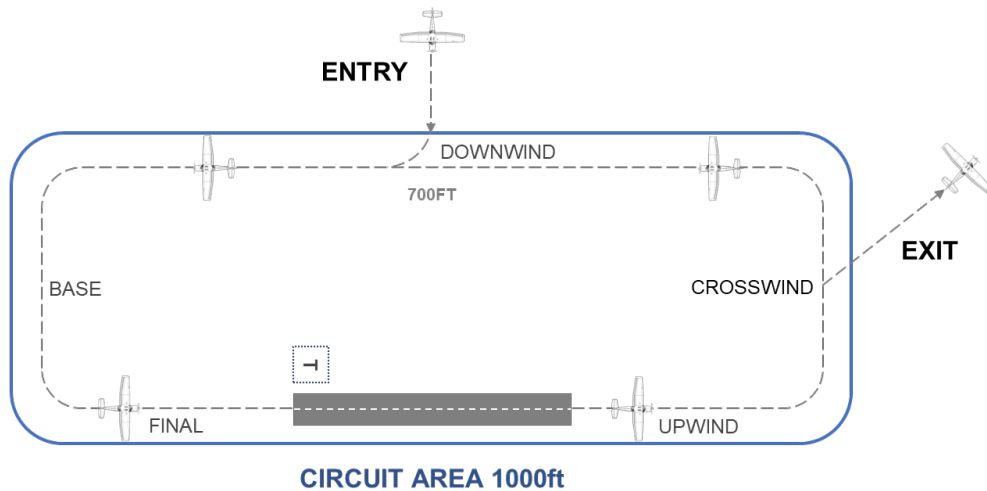

With every takeoff and landing runway there is a circuit area. The traffic circuit as depicted above, is inside the circuit area. The aerodrome circuit area is established for each runway. The lateral dimensions are also dependent on the local circumstances. The standard aerodrome traffic circuit as depicted above is situated within the aerodrome circuit area. The vertical dimensions extend from aerodrome level up to 1000 ft AAL. The traffic circuit is flown at 700 ft AAL.

Before executing the joining of the aerodrome traffic circuit, pilots have to take notice of the signals displayed in the signal area or of the information given by radio. Overflying the circuit area for observing the signal area shall be done at a height of at least 1000 ft AAL.

Within the aerodrome traffic circuit it is not allowed to overtake other aircraft.

Other arial activities may take place above this altitude. Climbing or descending to cruising level must take place outside the lateral limits of the aerodrome circuit area.

The joining of the standard aerodrome traffic circuit shall take place half-way downwind leg at an interception angle of 90° (the right of way rules when joining the circuit and if somebody is on downwind already, the best way of acting can be flying 360° for spacing in direction of downwind).

Leaving of the aerodrome traffic circuit shall take place at an angle of 45° half-way crosswind leg unless local circumstances force to establish another route which will be promulgated separately.

At those aerodromes where gliding activities take place, special procedures may be in place to reduce the risk of collision with winching cables.

➔ *Reference AIP, AIS-NETHERLANDS.NL. ENR 1.2 - 8 CIRCUIT PROCEDURES FOR AERODROME TRAFFIC*

➔ *ICAO Doc 4444 PANS-ATM*

➔ *ICAO Doc 9432 Manual of Radiotelephony*

**NOTE:** If there is no ATC or radio online you can overfly the airport and determine which runway is in use from the signal area, do this at a minimum of 1000 ft AAL. However, the local situation might dictate otherwise, e.g., at Hilversum due to gliders or paras. (ref AIP)

## Takeoff procedures

### Normal takeoff

**NOTE:** Hard surface, no flaps

Short runway (<800m) or soft surface: flaps 10°

- Before entering the runway, ensure base, final and runway are clear
- Line-up checks before or passing the hold short line or entering the runway
  - Check correct runway
  - Flaps checked
- Line up with centerline (check compass or heading indicator/G5)
- Check windsock, control column into the wind
- PITD (end of runway)
- Heels on the floor, feet of brakes!
- Smoothly advance throttle full forward, control direction with rudder pedals.
- Check and call out “engine instruments checked” and “airspeed alive”
- Reduce aileron input with increasing speed, maintain wings level
- Rotate at 55 kts, maintain wings level, nose against horizon
- If needed establish a drift correction angle to stay above the (extended) centerline
- Allow airspeed to increase to 70 kts
- Take a new PITD when the runway end disappears under the nose
- 200 ft check/select flaps UP, airspeed 80 kts
- Full power, keep hand on throttle
- Trim off forces
- Climb to 700 ft AAL. A climbing turn to crosswind leg is allowed, if necessary to stay within the aerodrome traffic circuit area (Ref. AIP Part 2, 1.2.8.6)
- At 700 ft, reduce power setting to  $\pm 1900$  RPM, 80 kts
- Trim off forces
  
- WHEN LEAVING THE CIRCUIT
  - Exit the pattern as prescribed and resume climb when clear of the circuit area
  - Landing light off (if applicable)
  
- WHEN STAYING IN THE CIRCUIT
  - Look for traffic and turn to crosswind
  - Proceed with the CIRCUIT AND NORMAL LANDING PROCEDURE

## Soft or rough field takeoff

- (1) Keep yoke full back during taxi
- (2) Select Flaps 10°, make a rolling takeoff, full throttle, yoke full aft, check engine instruments in the green, check airspeed alive
- (3) As airspeed increase, nose rises of ground, yoke moves forward to keep nosewheel just off the ground
- (4) The airplane flies itself of the ground in a slightly tail-low attitude
- (5) Accelerate in ground effect
- (6) 65 kts, gently raise nose to climb attitude
- (7) Accelerate to  $V_y$
- (8) Continue as normal takeoff, At 200 ft AGL: select flaps UP, airspeed 80 kts

Figure 18 – Soft or rough field takeoff

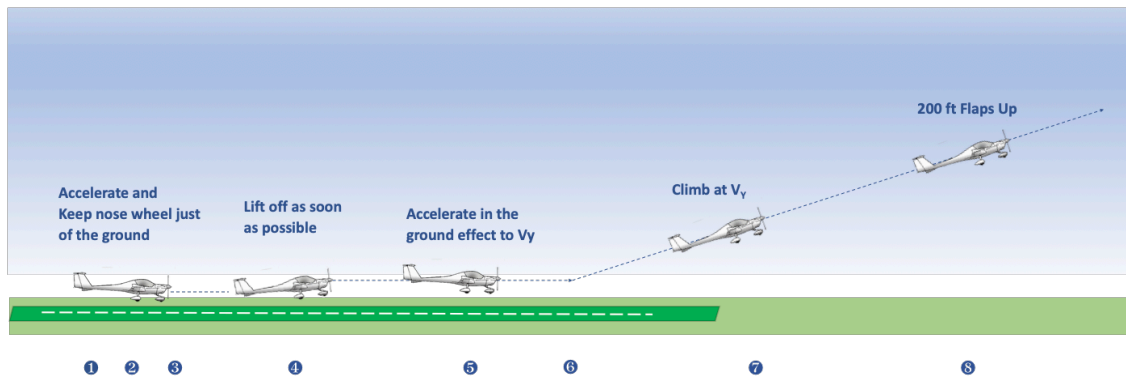

## Obstacle clearance takeoff (short field takeoff)

If for safety reason a “obstacle clearance takeoff” is required, consider all safety aspects: engine failure, loss of power, ability to see other traffic, etc. if all aspects are considered, and a decision is made to perform a obstacle clearance takeoff, proceed as below.

- (1) Select flaps 10°
- (2) Hold brakes, advance throttle FULL forward, check engine instruments in the green
- (3) Release brakes, keep direction with rudder pedals, check airspeed alive
- (4) Rotate at 50 kts
- (5) Climb with 60 kts  $V_x$
- (6) When free of all obstacles: lower nose attitude and accelerate to  $V_y$
- (7) Continue as normal takeoff At 200 ft AGL: select flaps UP, accelerate to 80 kts

Figure 19 – Obstacle clearance takeoff

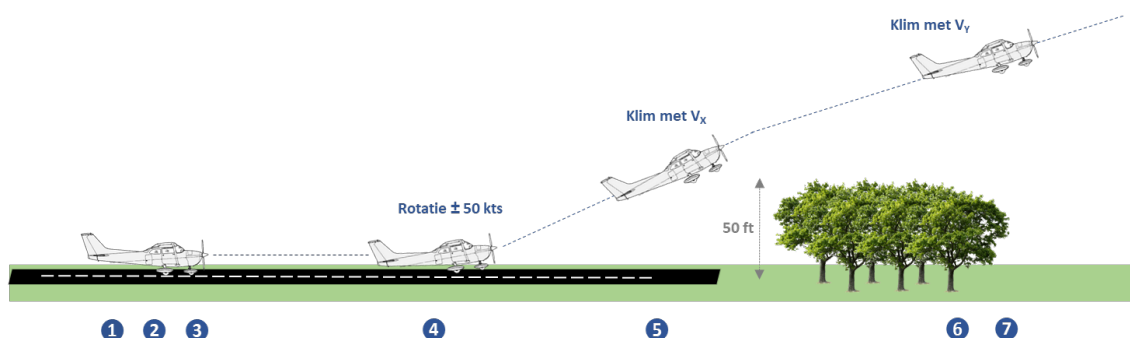

---

## Enroute procedures

### Enroute climb

- ✓ Airspeed                      BEST RATE ( $V_y$ ) or 80 kts
- ✓ Throttle                        FULL OPEN
- ✓ Mixture                        LEAN above 3000 ft, RICH below 3000 ft

### Cruise

- ✓ Power                            75% or LESS
- ✓ Elevator trim                    ADJUST
- ✓ Rudder trim (if installed)    ADJUST
- ✓ Mixture                        LEAN

### Approach

- ✓ Altimeter                        SET QNH
- ✓ Primer                          CLOSED AND LOCKED
- ✓ Magnetos                        BOTH
- ✓ Landing light                    ON
- ✓ Mixture                        RICH
- ✓ Fuel selector                    BOTH
- ✓ Brakes                          CHECKED
- ✓ Seat belts                        FASTENED

### Downwind check

- ✓ Carburetor heat                    ON
- ✓ Flaps                            Call out: "Speed checked" (speed below VFE) 10°
- ✓ Engine instruments / fuel quantity    CHECKED

**NOTE:** Downwind checks may be done after the Approach checks before joining the actual downwind or on the beginning of downwind when remaining in the circuit after takeoff / touch & go / go-around

## Landing procedures

### Circuit and normal landing

Entering the circuit or remaining in the circuit after takeoff, touch & go or go-around

- (1) At 700 ft, speed 80 kts, throttle  $\pm$ 1900 RPM
- (2) Look for traffic, turn downwind or look for joining traffic when staying in the circuit
- (3) On downwind continuously check "HARS"
  - Hoogte (Altitude)
  - Afstand (Offset from runway)
  - Richting (Direction parallel to runway)
  - Snelheid (Airspeed 80 kts)
- (4) If joining the circuit accomplish the before joining circuit check and downwind check before joining, if staying in the circuit: only DOWNWIND CHECK
  - Carburetor heat ON
  - Flaps (check airspeed below  $V_{FE}$ ) Call out: "Speed checked", flaps 10°
  - Maintain speed 75 kts
  - Engine instruments/fuel quantity CHECKED
- (5) Threshold 45° - 60° behind the wing Reduce throttle to  $\pm$ 1500 RPM and set nose attitude to maintain 75 kts
- (6) Turn base leg with 15°- 20° bank angle (max 30°)
- (7) call out: "Speed checked" and Select 20° flaps and trim to maintain 70 kts, look for traffic on final
- (8) Approximately at 500 ft and 20° before the extended centerline, turn final with 15° bank angle (max 20°)
- (9) Roll out on centerline, established at 300ft
- (10) FINAL CHECK:
  - Flaps Call out: "Speed checked", flaps 30°
  - Maintain speed 70-60 kts
- (11) Look for traffic, speed 60 kts on short final (see normal landing)

**NOTE:** Normal minimum speed over the threshold is 60 kts, corrections up to -5 to +15 kts may be made to account for runway conditions or wind, turbulent weather, windshear. Be aware that landing distance changes for different speeds!

Figure 20 – Standard Circuit

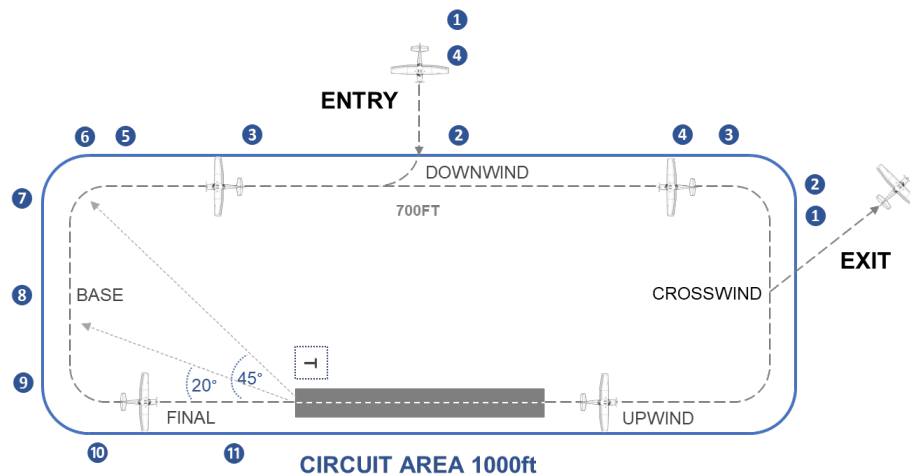

### Normal landing

- (1) Position the aircraft on a  $\pm 3^\circ$  glidepath and aim just before the threshold
- (2) As the aircraft gets closer to the runway, shift eyesight towards the end of the runway
- (3) After passing the threshold reduce vertical speed (round out). (On shorter general aviation runways the round might start before the threshold like it is depicted in the graph below)
- (4) Establish horizontal flight about 1m above the runway and simultaneously close the throttle
  - NOTE: On shorter runways, close the throttle earlier — during the round out phase — to avoid floating too far down the runway.
- (5) Use ailerons to maintain wings level and rudder to keep longitudinal axis aligned with the centerline
- (6) As airspeed reduces, increase nose attitude to maintain altitude (flare)
- (7) Land the airplane on the main gear
- (8) Aileron into the wind to keep the wings level
- (9) Keep the yoke in position where the airplane touched down, due to reducing airspeed the nosewheel will land itself
- (10) Gentle braking if necessary
- (11) Stop the airplane when clear of the runway and perform the after landing checklist

Figure 21 – Normal Landing

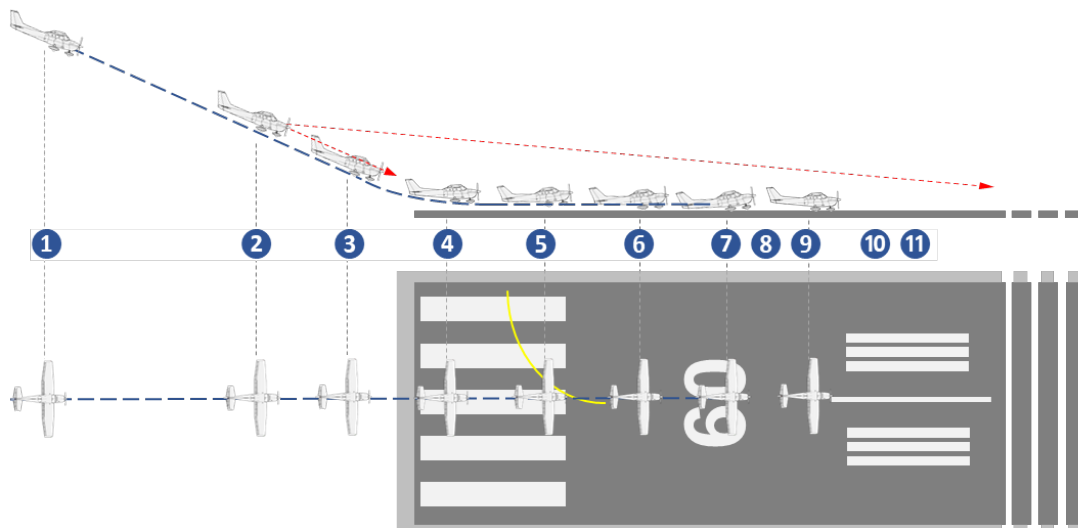

**WARNING**

**NOTE:** Do not brake excessively in order to exit the runway sooner, this may lead to blown tires!

## Flaps up landing

- Fly a standard circuit
- When turning baseleg reduce throttle to 1500 RPM
- Fly a normal circuit (see circuit), with the exception that:
- No flaps will be selected
- The speeds respectively are:
  - Downwind: 80 kts
  - Base: 75 kts
  - Final: 70 kts
- Execute a normal landing except:
- Nose attitude is higher than normal landing

- Aim for the landing spot
- Close throttle gently before approaching flare altitude and use only a very shallow roundout
- Take into account that due to the flapless condition:
  - The airplane responds more directly to control inputs
  - The airplane has a tendency to float
  - More runway length is needed

**NOTE:** Normal minimum speed over the threshold is 70 kts, corrections up to -5 to +15 kts may be made to account for runway conditions or wind, turbulent weather, windshear. Be aware that landing distance changes for different speeds!

## Soft field landing

A soft surface runway has more friction compared to a hard surface runway. When the main gear touches, the airplane has the tendency to slow down immediately and for the nose gear to lower to the ground. Try and keep the nose gear off as long as possible.

- Fly a standard circuit and normal final
  - Maximize the flare and after landing maintain full back pressure on the yoke
  - After landing and during taxi, keep the yoke fully aft
- (1) Position the aircraft on a  $\pm 3^\circ$  glidepath and aim just before the threshold
  - (2) As the aircraft get's closer to the runway, shift eyesight towards the end of the runway
  - (3) After passing the threshold reduce vertical speed (round out)
  - (4) Establish horizontal flight about 1m above the runway and simultaneously close the throttle
  - (5) Use ailerons to maintain wings level and rudder to keep longitudinal axis aligned with the centerline
  - (6) As airspeed reduces, increase nose attitude to maintain altitude (flare)
  - (7) Land the airplane on the main gear
  - (8) Aileron into the wind to keep wings level
  - (9) Increase back pressure on the yoke to keep the nose gear of the ground as long as possible
  - (10) Only brake when required by field length
  - (11) Keep rolling until a hard surface is reached if possible.

Figure 22 – Soft-field Landing

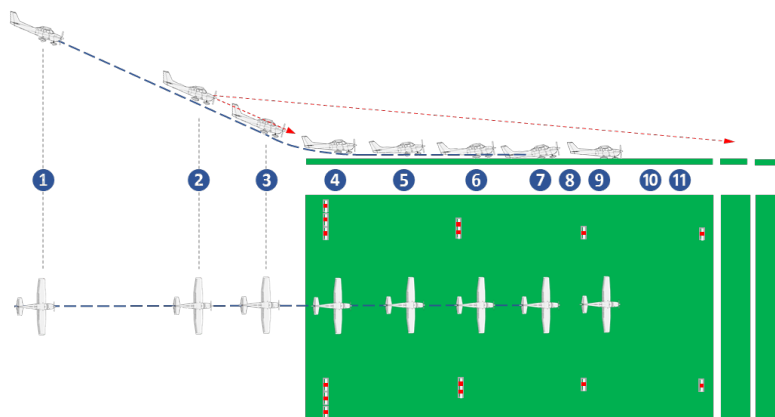

## Short field landing

- Fly a standard circuit
- After turning final select full flaps
- Reduce throttle to  $\pm 1400$  RPM
- Maintain an approx.  $3^\circ$  glidepath and aim slightly in front of the threshold
- Nose attitude to maintain 60 kts, Throttle to maintain glidepath
- speed 55 kts on short final
- Make a normal landing
- After the nosewheel has landed, select flaps UP (this reduces lift, increases braking action) and brake carefully

**NOTE:** Normal minimum speed over the threshold is 55 kts, corrections up to -5 to +15 kts may be made to account for runway conditions or wind, turbulent weather, windshear . Be aware that landing distance changes for different speeds!

## Go-around, balked landing

There is always a possibility that the runway is not clear or that you are not stabilized on final. In such a case, it is good airmanship to discontinue the landing attempt. A good option is to perform a go-around. The procedure is the same for hard and soft surface runways.

- State "go-around!"
- Smoothly advance throttle FULL, carburetor heat OFF
- Simultaneously raise the nose to make the rate of descent disappear
- Immediately select flaps  $20^\circ$
- Safe speed, minimum 55 kts, set nose just below normal climb attitude
- Check positive rate, select flaps  $10^\circ$ , climb with 60 kts  $V_x$  until obstacles are cleared
- Minimum 200 ft and speed 60 kts, flaps up and accelerate to  $V_y$
- If necessary to keep other traffic in sight, a turn to the dead side of the runway should keep you clear of other circuit traffic. However, the local situation might dictate otherwise e.g. at Hilversum due to gliders or para's. Choose the safest course of action.
- Continue as normal takeoff procedure (from the "Smoothly advance throttle full forward" step onward)
- Keep a good lookout for other traffic

**WARNING**

During the go-around it may happen that other traffic gets obscured by the airplane wings and disappear from view. Try to avoid this!

## Touch and go

On final include in R/T call your intention for touch and go.

After performing a landing including touchdown of the nosewheel, perform the following:

- Maintain direction
- Set flaps
  - Flaps 10 on grass
  - Flaps UP on paved runway (considering distance available)
  - In case of flapless landing, maintain flaps UP
- Set FULL power while setting carburetor heat OFF (when remaining distance is marginal, set FULL power first before above steps)
- Continue according to normal takeoff procedure

## Circuit with low ceilings/visibility weather

- Always remain clear of clouds
- Adjust traffic circuit altitude if necessary
- Maintain enough ground visibility
- Don't fly a wide pattern, do not lose sight of the runway
- Check direction of flight with heading indicator
- Do not continue into marginal VFR weather

## Circuit with turbulent weather

- Fly a standard pattern as much as possible (see circuit)
- Try and maintain normal altitudes and airspeed without trying too hard to hold on
- Consider a flaps up landing because of greater controllability (Flaps up landing)
- Consider to increase airspeed above normal airspeed on base and final

## Crosswind techniques

The maximum demonstrated crosswind component is 15 kts

### During takeoff:

- Yoke into the wind (maximum deflection)
- With increasing speed reduce yoke input to maintain wings level
- Maintain directional control with rudder (aircraft tends to weathervane, so with wind from left nose wants to turn left, with wind from the right, nose wants to turn right). Rotate at a slightly higher airspeed than normal, this ensures a positive lift off and minimizes the risk of settling back on the runway.

### After takeoff:

- After rotation reduce rudder input while simultaneously reducing stick input to normal. Airplane should self-establish correct drift angle. Make small adjustments if necessary.

### During the circuit:

- Establish drift angle to correctly fly the circuit over the ground.

### During the landing:

- After closing the throttle / during the round out and flare align the longitudinal axis with the runway centerline
- Simultaneously input aileron into the wind to counteract any tendency to drift to the side
- Keep looking towards the end of the runway
- Make small corrections with the rudder to keep the longitudinal axis aligned
- Make small corrections with the ailerons to keep the airplane above the centerline
- Flare normally
- The main gear on the upwind side touches first, then the other main gear and the nose gear last
- With a strong crosswind it may be advisable to execute a flapless landing

Figure 24 – Crosswind

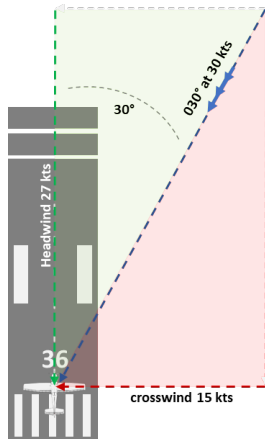

**Example:**

Wind : 030°/ 30 kts  
Runway 36 (360°)

**What is the crosswind?**  
 $\sin 30^\circ = 0.5 \Rightarrow 0.5 \times 30 \text{ kts} = 15 \text{ kts crosswind. (max Cessna 172)}$

**Rules of thumb:**

- If the wind 30° to the rwy, crosswind is about 50% of the wind speed.
- If the wind 45° to the rwy, crosswind is about 70% of the wind speed.
- If the wind 60° to the rwy, crosswind is about 90% of the wind speed.
- If the wind is more than 60° to the rwy, crosswind is the total wind.

**What is the headwind?**

$\cos 30^\circ = 0.9 \Rightarrow 0.9 \times 30 \text{ kts} = 27 \text{ kts Headwind}$

## Abnormal procedures

First and foremost: maintain airplane control, fly the airplane!!

### Rejected takeoff

**NOTE:** Commence a rejected takeoff if a situation arises before rotation that makes a continued takeoff unsafe or impossible

- Call out "STOP"
- Close the throttle, use rudder pedals to maintain centerline, flaps up
- If required, use brakes
- Report situation over radio and state intentions

### Engine failure after takeoff (EFATO)

The goal of the simulated engine failure after takeoff is to prepare the student for a real engine failure after takeoff. The simulated engine failure is initiated by the instructor by closing the throttle and calling out "simulated engine failure". React promptly and correctly, the procedures should be done quickly.

#### WARNING

If it is a simulated exercise don't turn anything off! Point to switches and controls (touch-drill only!). The exercise should not be initiated below 300 ft AGL.

- Immediately lower nose to glide attitude, (60 flaps 10° kts) 65 kts
- Choose a suitable landing site 30° left/right from the nose
- Use minimum bank angles to avoid obstacles
- If possible, do a short failure check (touch drill only!):
- Ignition both
- Carburetor heat ON
- Mixture full rich
- Fuel selector open
- Accomplish an emergency landing without power using (full) flaps, if required
- The instructor will end the exercise with the call out "Go-around".

## Engine failure during flight

- Maintain altitude until airspeed has reduced to 65 kts (see figure 25b best glide speed)
- Lower nose attitude to position for glide, maintain speed 65 kts
- Perform engine failure memory items (touch drill only!):
  - Airspeed 65 KIAS
  - Carburetor heat ON
  - Fuel selector valve BOTH
  - Mixture RICH
  - Ignition switch (Start if propeller is stopped) BOTH
  - Primer IN & LOCKED
- If engine fails to start
  - Emergency landing without engine power EXECUTE

## Emergency landing without engine power

The simulated engine failure is initiated by the instructor by closing the throttle and stating “simulated engine failure”.

### WARNING

If it is an exercise, don't turn anything off! Point to the switches and controls (touch-drill only!)

- Maintain altitude until airspeed has reduced to 65 kts (see figure 25b best glide speed)
- Lower nose attitude to position for glide, maintain speed 65 kts
- Trim of forces
- Check wind direction
- Make a plan and depending on altitude and position fly direct to downwind, base or final
  - > 1500 ft downwind with 1000 ft punt
  - < 1500 ft direct base
  - < 700 ft direct final
- Accomplish a failure drill (if not already done in previous procedure)
  - Carburetor heat ON
  - Fuel selector valve BOTH
  - Mixture FULL RICH
  - Ignition (start if propellor is stopped) BOTH
  - Primer IN AND LOCKED
- Check engine instruments and fuel quantity
- Choose a suitable landing site within range and into the wind
- In case of downwind procedure pick a 1000 ft point abeam the threshold
- Mayday call, ELT ON manually, transponder code 7700
- Check:
  - Nose attitude / airspeed 65 kts, forces trimmed off
  - Coordinated flight (ball centered, required due to loss of left turning tendency)
  - Route and altitude
- Threshold between 30° and 45° behind wing (depending on wind and altitude), turn base
- Aim for 1/3 off the landing field
- When assured landing can be made on 1/3 of the field, check speed within white arc, call out: “Speed checked” and lower flaps in stages

- Plan a full flap landing with 60 kts
  - Note: Depending on circumstances (gliding distance to field, wind speed/direction etc) a flaps up landing might be required.
- After selecting full flaps, aim for the threshold
- When certain engine is not going to start and final flaps set;
  - CRASH DRILL:

**WARNING**

If it is an exercise, don't turn anything off! Point to the switches and controls (touch-drill only!)

- Mixture IDLE CUT OFF
  - Fuel selector valve OFF
  - Ignition switch OFF
  - Wing flaps AS REQUIRED
  - Master switch OFF
  - Doors UNLATCH
  - Belts/loose equipment FASTENED/STOWED
- Accomplish a short/soft field landing

Figure 25 – Emergency landing without engine power

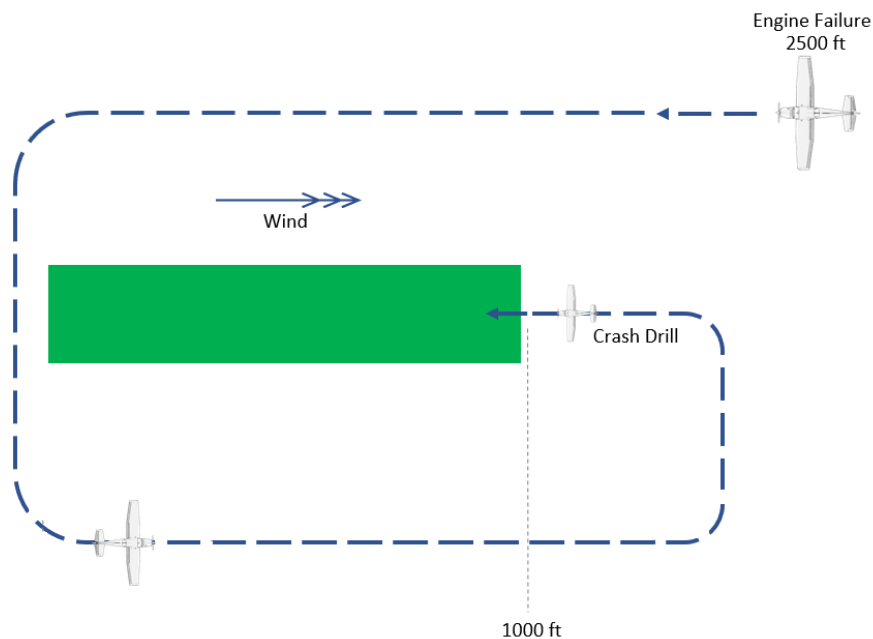

## Estimated gliding distance

The maximum L/D-ratio ( $L/D_{max}$ ) off a Cessna is approximately 9, so the glide ratio is approximately 9:1 – meaning for every unit down the forward travel is 9 units. the Cessna 172 will glide approx. 9.000 feet (1.5 NM) for every 1.000 feet available altitude. This is a typical value for the Cessna 172.

Figure 26a – Estimated gliding distance (not to scale)



Figure 26b – Best glide speed

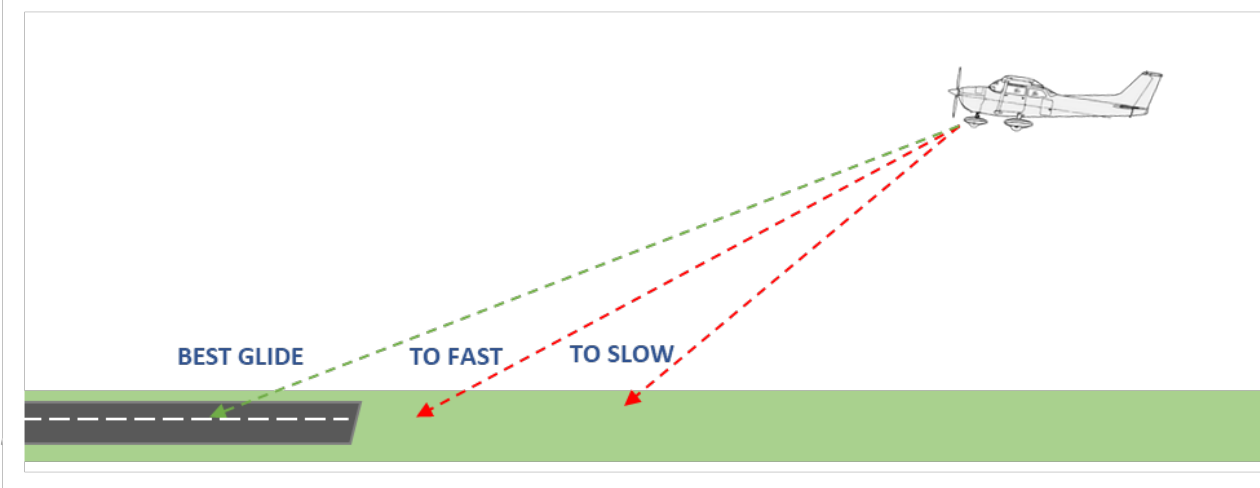

## Wind affects gliding range over the ground

Figure 27a – Gliding Distance - no wind (not to scale)

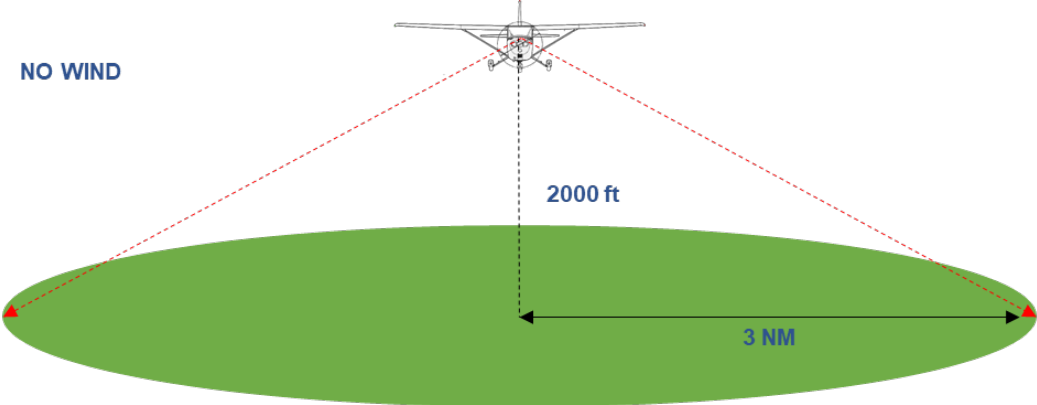
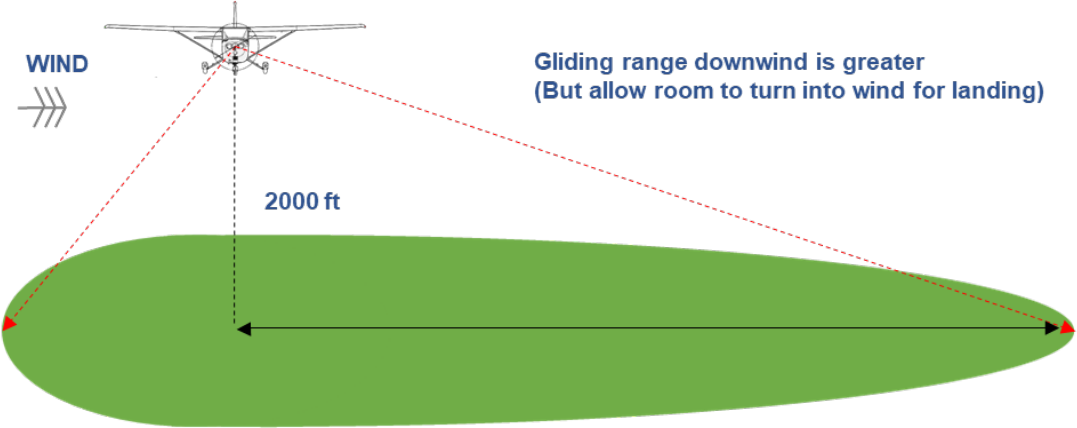

Figure 27b – Gliding Distance - with wind (not to scale)



## Precautionary landing

The airplane must be in good technical condition for this procedure, if not, see emergency landing without power.

Only fly mentioned altitudes if cloud base and visibility allow this.

- BEFORE JOINING THE CIRCUIT checks
- Descend to 500 ft and turn downwind
- Choose a suitable landing site into the wind
- PAN PAN call
- Position the aircraft on a 500 ft downwind, carburetor heat ON, flaps 10°, ±1900 RPM
- Turn to base and start descending, throttle to ±1500 RPM
- Turn to final and level off at 200 ft
- Advance throttle to ±1900 RPM, airspeed 75 kts, STOP DESCENT!
- Accomplish an inspection run abeam the field and start timing and check:
  - Slope
  - Obstacles
  - Length (see Figure 27b timing table)
  - Landing site condition
  - Obstacle free final and takeoff leg
- Start a go-around procedure at the end of the field
- Climb back to circuit altitude 500 ft
- Level off, throttle ±1900 RPM, airspeed 80 kts
- Turn crosswind and subsequently downwind
- DOWNWIND CHECK
 

– Carburetor heat	ON
– Flaps (check speed below VFE)	Call out: “Speed checked”, flaps 10°, maintain speed 75 kts
– Engine instruments/fuel quantity	CHECKED
- Threshold 45° - 60° behind the wing
- Turn base leg with 15° - 20° bank angle (max 30°), throttle to ±1500 RPM when intercepting the glidepath
- Call out: “Speed checked” and Select 20° flaps and trim to maintain 70 kts
- Approximately 20° before the extended centerline, turn final with 15° bank angle (max 20°)
- Roll out on centerline
- FINAL CHECK:
 

– Flaps	Call out: “Speed checked”, flaps 30°
---------	--------------------------------------
- Maintain approach speed 60 kts
- Speed 55kts on short final, accomplish a short/soft field landing

**NOTE:** Normal minimum speed over the threshold is 55 kts, corrections up to -5 to +15 kts may be made to account for wind, turbulent weather windshear or runway conditions. Be aware that landing distance changes for different speeds!

Figure 28a – Precautionary landing with engine power

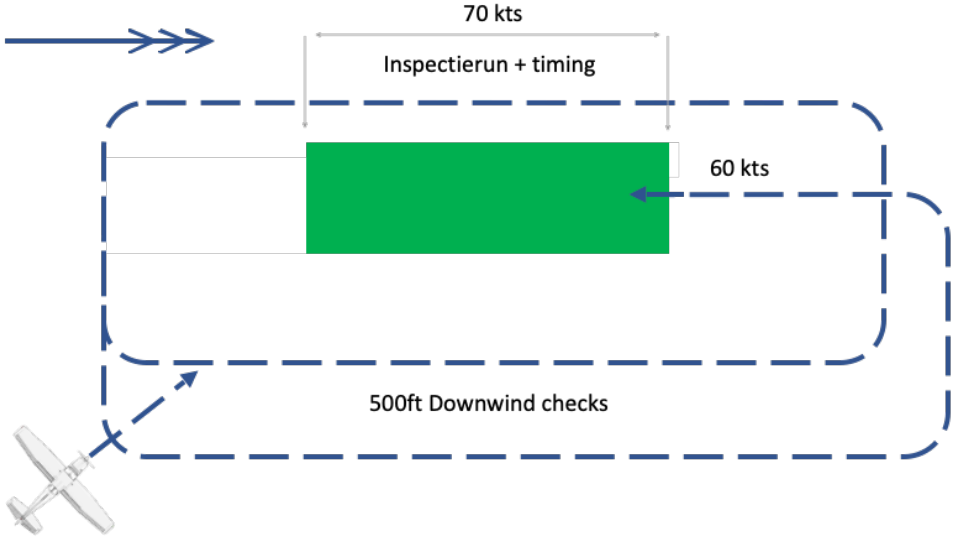

Figure 28b – Precautionary landing – Inspection run, timing and distance table

INSPECTION RUN + TIMING		
Minimal landings distance @500m		
Ground speed	Meters per seconds	Amount of seconds to time
60kts	31 m/s	16
70kts	36 m/s	14
80kts	41 m/s	12
90kts	46 m/s	11

## Important links

ACHA Aero Club Hilversum-Amsterdam:

- <https://vliegclubhilversum.nl/>

Vliegveld Hilversum:

- <http://www.ehvh.nl/>

AIS-publicaties:

- <https://www.lvnl.nl/informatie-voor-luchtvaardenden/publicaties-voor-luchtvaardenden>

MILAIP:

- <https://english.defensie.nl/topics/m/milaip-military-aeronautical-information-publication>

NOTAMS / Flightplan /

- <https://www.homebriefing.nl>

METEO:

- <https://www.luchtvaartmeteo.nl/>

EASA Regulations:

- <https://www.easa.europa.eu/regulations>

SKYBRARY

- <https://skybrary.aero/>

**Notes:**

## APPENDIX

### Checklist PH-DON

#### NORMAL CHECKLISTS C-172 PH-DON

Note: Checks in blue are to be performed by memory!

##### BEFORE STARTING ENGINE

Gust lock & pitot cover ..... REMOVED & STOWED  
 Walk-around and visual inspection ..... COMPLETED  
 Aircraft documents ..... ON BOARD  
 Seats & seatbelts ..... ADJUSTED & SECURED  
 Doors & windows ..... CLOSED & LOCKED  
 Parking brake ..... SET  
 Fuel selector ..... BOTH  
 All electrical switches ..... OFF  
 Avionics master switch ..... OFF  
 Circuit breakers ..... IN  
 Master switch ..... ON  
 Fuel quantity ..... CHECKED  
 HOBBS & VUT ..... NOTED  
 Departure/pax briefing ..... COMPLETED

##### STARTING ENGINE

Mixture ..... RICH  
 Carburetor heat ..... OFF  
 Prime ..... AS REQUIRED & LOCKED  
 Throttle ..... 1 CM  
 Beacon light ..... ON  
 Propeller ..... CLEAR  
 Ignition switch ..... START

##### AFTER STARTING ENGINE

Throttle ..... 1000 RPM  
 Oil pressure ..... CHECK  
 Starter warning light ..... OFF  
 Ammeter ..... CHARGING (+)  
 Flaps ..... UP  
 Avionics master switch ..... ON  
 Radio equipment & transponder ..... ON/SET/STBY  
 Flight instruments ..... SET & CHECKED  
 Parking brake ..... RELEASE

##### DURING TAXIING

Brakes ..... CHECK  
 Instruments ..... CHECK

##### ENGINE RUNUP

Throttle ..... 1000 RPM  
 Parking brake ..... SET  
 Check behind ..... CLEAR  
 Throttle ..... 1700 RPM  
 Engine instruments ..... CHECK  
 Carburetor heat ..... (check RPM drop) ON  
 Carburetor heat ..... (RPM back to 1700) OFF  
 Magnetos ..... (drop 125 rpm, diff. 50) R / BOTH / L / BOTH  
 Ammeter ..... CHARGING (+)  
 Throttle idle ..... ±700 RPM  
 Throttle ..... 1000 RPM  
 Throttle friction ..... SET

##### BEFORE TAKE-OFF

Flight controls ..... CHECKED  
 Rudder & elevator trim ..... SET FOR TAKE OFF  
 Flaps ..... (Grass, 10°) SET FOR TAKE OFF  
 Transponder ..... ALT  
 Landing light ..... ON  
 Strobe light ..... ON  
 Pitot heat ..... AS REQUIRED  
 Take-Off briefing ..... COMPLETED  
 Parking brake ..... RELEASE

#### VFR DAY AND NIGHT ONLY



##### AFTER TAKE-OFF (Above 200ft AAL)

Flaps ..... UP  
 Landing light ..... OFF

##### APPROACH

Approach briefing ..... COMPLETED  
 Altimeter ..... SET QNH  
 Primer ..... CLOSED AND LOCKED  
 Magnetos ..... BOTH  
 Landing light ..... ON  
 Mixture ..... RICH  
 Fuel selector ..... BOTH  
 Brakes ..... CHECKED  
 Seat belts ..... FASTENED  
 Loose Items ..... STOWED

##### DOWNWIND (70 kts)

Carburetor heat ..... ON/WARM  
 Flaps ..... (<110 kts) 10°  
 Engine instruments/fuel quantity ..... CHECKED

##### BASE LEG (70 kts)

Flaps ..... 20°

##### FINAL (approach speed 60 kts)

Flaps ..... AS REQUIRED

##### BALKED LANDING

Throttle ..... FULL  
 Carburetor heat ..... OFF  
 Flaps ..... 20°  
 Speed ..... MIN 55 kts

##### AFTER LANDING

Flaps ..... UP  
 Carburetor heat ..... OFF  
 Landing light ..... OFF  
 Strobe lights ..... OFF  
 Transponder ..... STBY  
 Pitot heat ..... OFF

##### AFTER PARKING

Throttle ..... 1000 RPM  
 Parking brake ..... SET  
 Avionics master switch ..... OFF  
 All electrical switches (Except Beacon Light) ..... OFF  
 Mixture ..... IDLE CUT OFF  
 Beacon light ..... OFF  
 Ignition ..... OFF AND KEY REMOVED  
 Master switch ..... OFF  
 HOBBS & VUT ..... NOTED  
 Emergency locator transmitter ..... NOT TRIGGERED  
 Gust lock & pitot cover ..... INSTALL  
 Check the aircraft and windows for dirt and clean if necessary.



AEROCLUB HILVERSUM-AMSTERDAM



NL-ATO-227

## ABNORMAL CHECKLISTS C-172 PH-DON

Note: Checks in red are to be performed by memory!

### ENGINE FAILURES:

#### ENGINE FAILURE DURING TAKEOFF RUN

Throttle.....IDLE  
Brakes.....APPLY  
Flaps.....RETRACT  
Mixture.....IDLE CUT OFF  
Ignition switch.....OFF  
Master switch.....OFF

#### ENGINE FAILURE IMMEDIATELY AFTER TAKEOFF

Airspeed.....(flaps down) 60 kts  
.....(flaps up) 65 kts  
Mixture.....IDLE CUT OFF  
Fuel selector valve.....OFF  
Ignition switch.....OFF  
Flaps.....AS REQUIRED  
Master switch.....OFF  
Forced landing.....EXECUTE

#### ENGINE FAILURE DURING FLIGHT

Airspeed.....65 kts  
Carburetor heat.....ON/WARM  
Fuel selector valve.....BOTH  
Mixture.....RICH  
Ignition switch.....(START if propeller is stopped) BOTH  
Primer.....IN AND LOCKED  
(If engine fails to start)  
Forced landing.....EXECUTE

### ENGINE FIRES:

#### FIRES DURING START ON GROUND

Cranking.....CONTINUE  
**IF ENGINE STARTS:**  
Throttle.....1700 RPM FOR A FEW MINUTES  
Mixture.....IDLE CUT OFF  
**IF ENGINE FAILS TO START:**  
Throttle.....FULL OPEN  
Mixture.....IDLE CUT OFF  
Cranking.....CONTINUE  
Engine.....SECURE  
Master switch.....OFF  
Ignition switch.....OFF  
Fuel selector valve.....OFF

#### ENGINE FIRE IN FLIGHT

Mixture.....IDLE CUT OFF  
Fuel selector valve.....OFF  
Master switch.....OFF  
Cabin heat and air.....(except overhead vents) OFF  
Airspeed.....100 kts  
(if fire is not extinguished, increase glide speed to find an  
airspeed which will provide an incombustible mixture)  
Forced landing.....EXECUTE

## VFR DAY AND NIGHT ONLY



### ELECTRICAL FIRE IN FLIGHT

Master switch.....OFF  
Avionics power switch.....OFF  
All other switches (except ignition).....OFF  
Vents/cabin air/heat.....CLOSED  
if fire appears out and electrical power is necessary for  
continuance for flight  
Master switch.....ON  
Circuit breakers.....CHECK  
for faulty circuit, do not reset

Radio switches.....OFF  
Avionics power switch.....ON  
Radio/electrical switches.....ON  
one at a time, with delay after each until short circuit  
is localized  
Vents/cabin air/heat.....OPEN  
when it is ascertained that fire is completely extinguished

### CABIN FIRE

Master switch.....OFF  
Vents/cabin air/heat.....CLOSED  
Land.....AS SOON AS POSSIBLE

### ELECTRICAL POWER SUPPLY SYSTEM MALFUNCTIONS:

#### AMMETER SHOWS EXCESSIVE RATE OF CHARGE (Full Scale Deflection)

Alternator.....OFF  
Alternator circuit breaker.....PULL  
Non-essential electrical equipment.....OFF  
Land.....AS SOON AS PRACTICAL

#### LOW VOLTAGE LIGHT ILLUMINATES DURING FLIGHT (Ammeter indicates discharge)

(Illumination of the low-voltage light may occur during low RPM  
conditions with an electrical load on the system such as during a  
low RPM taxi. Under these conditions, the light will go out at  
higher RPM. The master switch need not be recycled since an  
over-voltage condition has not occurred to deactivate the  
alternator system)  
Avionics power switch.....OFF  
Alternator circuit breaker.....CHECK IN  
Master switch.....(both sides) OFF  
Master switch.....ON  
Low voltage light.....CHECK OFF  
Avionics powers switch.....ON

#### IF LOW VOLTAGE LIGHT ILLUMINATES AGAIN:

Alternator.....OFF  
Non-essential radio and electrical equipment.....OFF  
Land.....AS SOON AS PRACTICAL

### NOTE:

This checklist is a Recommended Operator Checklist and for  
reference only. It is not a substitute for and does not supersede  
the current approved Airplane Flight Manual.  
For a comprehensive listing see the Airplane Flight Manual.

## APPENDIX Checklist PH-JBC en Afwijkingen

### NORMAL CHECKLISTS C-172 PH-JBC

Note: Checks in blue are to be performed by memory!

#### BEFORE STARTING ENGINE

Gust lock & pitot cover .....REMOVED & STOWED  
 Walk-around and visual inspection .....COMPLETED  
 Aircraft documents ..... ON BOARD  
 Seats & seatbelts ..... ADJUSTED & SECURED  
 Departure/pax briefing.....COMPLETED  
 Doors & windows ..... CLOSED & LOCKED  
 Parking brake ..... SET  
 Fuel selector..... BOTH  
 All electrical switches ..... OFF  
 Avionics master switch..... OFF  
 Circuit breakers ..... IN  
 Master switch ..... ON  
 Fuel quantity..... CHECKED  
 HOBBS & VUT ..... NOTED

#### STARTING ENGINE

Mixture ..... RICH  
 Carburetor heat ..... OFF  
 Prime ..... AS REQUIRED & LOCKED  
 Throttle ..... 1 CM  
 Beacon light ..... ON  
 Propeller..... CLEAR  
 Ignition switch..... START

#### AFTER STARTING ENGINE

Throttle ..... 1000 RPM  
 Oil pressure ..... CHECK  
 Starter warning light ..... OFF  
 Ammeter..... CHARGING (+)  
 Flaps ..... UP  
 Avionics master switch..... ON  
 Radio equipment & transponder ..... ON/SET  
 Flight instruments ..... SET & CHECKED  
 Parking brake ..... RELEASE

#### DURING TAXIING

Brakes ..... CHECK  
 Instruments ..... CHECK

#### ENGINE RUNUP

Throttle ..... 1000 RPM  
 Parking brake ..... SET  
 Check behind ..... CLEAR  
 Throttle ..... 1700 RPM  
 Engine instruments ..... CHECK  
 Carburetor heat ..... (check RPM drop) ON  
 Carburetor heat ..... (RPM back 1700) OFF  
 Magnetos ..... (drop 125 RPM, diff. 50) R / BOTH / L / BOTH  
 Ammeter..... CHARGING (+)  
 Throttle idle ..... ±700 RPM  
 Throttle ..... 1000 RPM  
 Throttle friction ..... SET

#### BEFORE TAKEOFF

Flight controls..... CHECKED  
 Elevator trim ..... SET FOR TAKE OFF  
 Flaps ..... (grass 10°) SET FOR TAKE OFF  
 Transponder..... ALT  
 Landing light..... ON  
 Pitot heat ..... AS REQUIRED  
 Take-Off briefing ..... COMPLETED  
 Parking brake ..... RELEASE

#### VFR DAY ONLY



#### AFTER TAKEOFF (Above 200ft AAL)

Flaps ..... UP  
 Landing light ..... OFF

#### APPROACH

Approach briefing ..... COMPLETED  
 Altimeter..... SET QNH  
 Primer ..... CLOSED AND LOCKED  
 Magnetos ..... BOTH  
 Landing light ..... ON  
 Fuel selector ..... BOTH  
 Mixture ..... RICH  
 Brakes ..... CHECKED  
 Seat belts..... FASTENED  
 Loose Items ..... STOWED

#### DOWNWIND (70 kts)

Carburetor heat ..... ON/WARM  
 Flaps ..... (<87 kts) 10°  
 Engine instruments/fuel quantity ..... CHECKED

#### BASE LEG (70 kts)

Flaps ..... 20°

#### FINAL (70 - 60 kts)

Flaps ..... AS REQUIRED

#### BALKED LANDING

Throttle ..... FULL  
 Carburetor heat..... OFF  
 Flaps ..... 20°  
 Speed ..... Safe speed, min 55 kts

#### AFTER LANDING

Flaps ..... UP  
 Carburetor heat..... OFF  
 Landing light ..... OFF  
 Pitot heat ..... OFF

#### AFTER PARKING

Throttle ..... 1000 RPM  
 Parking brake ..... SET  
 Avionics master switch ..... OFF  
 All electrical switches (Except Beacon Light) ..... OFF  
 Mixture ..... IDLE CUT OFF  
 Beacon light..... OFF  
 Ignition ..... OFF AND KEY REMOVED  
 Master switch ..... OFF  
 HOBBS & VUT ..... NOTED  
 Emergency locator transmitter ..... NOT TRIGGERED  
 Gust lock & pitot cover ..... INSTALL  
 Check the aircraft and windows for dirt and clean if necessary.



AEROCLUB HILVERSUM-AMSTERDAM



NL-ATO-227

## ABNORMAL CHECKLISTS C-172 PH-JBC

Perform **RED AND BOLD** abnormal checklist items from memory

VFR DAY  
ONLY



### ENGINE FAILURES:

#### ENGINE FAILURE DURING TAKEOFF RUN

Throttle..... IDLE  
Brakes ..... APPLY  
Flaps ..... RETRACT  
Mixture ..... IDLE CUT OFF  
Ignition switch ..... OFF  
Master switch ..... OFF

#### ENGINE FAILURE IMMEDIATELY AFTER TAKEOFF

Airspeed ..... (flaps 10) 65 kts  
..... (flaps up) 70 kts  
Mixture ..... IDLE CUT OFF  
Fuel selector valve ..... OFF  
Ignition switch ..... OFF  
Flaps ..... AS REQUIRED  
Master switch ..... OFF  
Forced landing ..... EXECUTE

#### ENGINE FAILURE DURING FLIGHT

Airspeed ..... 70 kts  
Carburetor heat ..... ON/WARM  
Fuel selector valve ..... BOTH  
Mixture ..... RICH  
Ignition switch ..... (START if propeller is stopped) BOTH  
Primer ..... IN AND LOCKED  
(If engine fails to start)  
Forced landing ..... EXECUTE

### ENGINE FIRES:

#### FIRES DURING START ON GROUND

Cranking ..... CONTINUE  
**IF ENGINE STARTS:**  
Throttle ..... 1700 RPM FOR A FEW MINUTES  
Mixture ..... IDLE CUT OFF  
**IF ENGINE FAILS TO START:**  
Throttle ..... FULL OPEN  
Mixture ..... IDLE CUT OFF  
Cranking ..... CONTINUE  
Engine ..... SECURE:  
Master switch ..... OFF  
Ignition switch ..... OFF  
Fuel selector valve ..... OFF

#### ENGINE FIRE IN FLIGHT

Mixture ..... IDLE CUT-OFF  
Fuel selector valve ..... OFF  
Master switch ..... OFF  
Cabin heat and air ..... (except overhead vents) OFF  
Airspeed ..... 100 kts  
(if fire is not extinguished, increase glide speed to find an airspeed which will provide an incombustible mixture)  
Forced landing ..... EXECUTE

#### ELECTRICAL FIRE IN FLIGHT

Master switch ..... OFF  
Avionics power switch ..... OFF  
All other switches(except ignition) ..... OFF  
Vents/cabin air/heat ..... CLOSED

**if fire appears out and electrical power is necessary for continuance for flight**

Master switch ..... ON  
Circuit breakers ..... CHECK

**for faulty circuit, do not reset**

Radio switches ..... OFF  
Avionics power switch ..... ON  
Radio/electrical switches ..... ON

**one at a time, with delay after each until short circuit is localized**

Vents/cabin air/heat ..... OPEN  
**when it is ascertained that fire is completely extinguished**

#### CABIN FIRE

Master switch ..... OFF  
Vents/cabin air/heat ..... CLOSED  
Land ..... AS SOON AS POSSIBLE

### ELECTRICAL POWER SUPPLY SYSTEM MALFUNCTIONS:

#### INSUFFICIENT RATE OF CHARGE

**(Ammeter shows discharge during flight)**

Alternator ..... OFF  
Non-essential radio/electrical equipment ..... OFF  
Land ..... AS SOON AS PRACTICAL

#### EXCESSIVE RATE OF CHARGE

**Over voltage light is illuminated**

Avionics power switch ..... OFF  
Master switch ..... (both sides) OFF  
Master switch ..... ON  
Over voltage light ..... CHECK OFF  
Avionics power switch ..... ON

**IF OVER VOLTAGE LIGHT ILLUMINATES AGAIN:**

Land ..... AS SOON AS POSSIBLE

#### NOTE:

*This checklist is a Recommended Operator Checklist and for reference only. It is not a substitute for and does not supersede the current approved Airplane Flight Manual. For a comprehensive listing see the Airplane Flight Manual.*

## PH-JBC wijkt op een aantal punten af van PH-DON en PH-SKC

De JBC is gewoon een Cessna 172, maar wijkt op onderdelen iets af. Daarom is het goed je te verdiepen in die verschillen, voordat je ermee gaat vliegen.

Hier een korte opsomming, die je niet ontslaat van je eigen verantwoordelijkheid om kennis te nemen van de POH en de manuals van sommige avionica. Beiden op onze website terug te vinden onder <https://vliegclubhilversum.nl/flightplanning/checklists-manuals/>

### 1. Lay-out cockpit dashboard



De 4 motor gauges zitten rechtsboven, in plaats van linksonder.  
Globaal zitten de andere klokjes wel in de basic-six opstelling, met de G5 links van het midden in plaats van in het midden.



### 2. De radiostack kent deels andere apparatuur dan de beide andere Cessna's

## PH-JBC wijkt op een aantal punten af van PH-DON en PH-SKC



Boven in het Audio Control System, de KMA20 Zie de manual op

<https://vliegclubhilversum.nl/documents/2021/10/KMA20Audio-Control-System-PH-JBC.pdf>

De radio is gelukkig een bekende, de Garmin GNC 255A/255B.

De transponder is weer anders, een Garmin GTX 330/330D, die ook anders werkt dan de bekende Garrecht.

<https://vliegclubhilversum.nl/documents/2021/10/GarminTransponder-GTX-330-PH-JBC.pdf>

### 3. De Flaps

De 172M kent de oude maximale flapsetting van 40 graden. Bij de DON en de SKC is die teruggebracht naar 30 graden. Waarmee de MTOW iets omhooggaat.

Voor de JBC, in de serie 172M, bestaat nog geen 'supplemental type certificate' (STC) voor de wijziging van de flapsetting. Dus we kunnen de maximale flapsetting niet terugbrengen naar 30 graden. De MTOW voor de JBC blijft daardoor op 1.043 kg. Advies, gebruik de 40 graden setting standaard niet, tenzij je deze heel bewust wel wilt selecteren.

De bediening van de flaps is ook anders bij de JBC ten opzichte van onze andere Cessna. Het is een **traploze kantelknop**, die je naar beneden moet vasthouden, totdat je de gewenste klepsetting hebt verkregen. Rechtsboven deze knop, zit een meter waarop de graden zijn af te lezen, maar gewoon kijken en/of tellen kan ook. Omhoog is de knop naar boven trekken. Maar pas op (!) als de gewenste stand is bereikt, moet je de knop *actief* in de neutraal (midden) stand zetten. Als je dat vergeet, blijft de elektromotor lopen totdat de flapsetting nul is geworden. Dat kan vervelend uitkomen als je wilt doorstarten op short final. Dus check dat je de knop op neutraal zet als je de juiste setting hebt bereikt.

PH-JBC wijkt op een aantal punten af van PH-DON en PH-SKC



#### 4. Motor

De C-172M is uitgerust met een 150 pk motor (Lycoming O-320-E2D), in afwijking van de meer bekende 160 pk motor van de latere Cessna's. Zijn leeggewicht is ca 50 kg minder dan die van de SKC en DON. MTOW is 1.043 in tegenstelling tot de 1.092 kg van onze beide andere Cessna's. Bereken uiteraard de juiste W&B voor vertrek, op de site staat het nieuwste Excel voor het gemak van die calculatie.

[https://vliegclubhilversum.nl/documents/2021/12/W\\_and\\_B\\_Versie\\_7.04\\_FFIS.xls](https://vliegclubhilversum.nl/documents/2021/12/W_and_B_Versie_7.04_FFIS.xls)

Daarnaast is het Oil level anders; minimum is 6 Quarts, maximum is 8 Quarts. ■

#### 5. Deurklink

De deurklink zit verder naar achteren als je op de stoel zit. Even wennen om die goed te bedienen.

